

Technical data

Fuse Links NV/NH

Electrical characteristics	
Rated voltage U_n	400 V AC, 500 V AC, 690 V AC
Rated current I_n	2 - 1600 A
Breaking capacity U_n	120 kA, 100 kA, 50 kA
Melting characteristic	gG, aM, gF, gTr
Certified	DIN VDE0636-201 (1998-06)
In accordance with	IEC 60269-1:2005 / EN 60269-1:1998+A1:2005 IEC 60269-2:1986+Corr.1:1996+A11995+A2:2001 / EN 60269-2:1995+A1:1998+A2:2002 IEC 60269-2-1:2004 / HD 60269-2-1:2005
Dimensions according to	DIN43620 Part: 1 - 4
Two versions of covers	aluminium and plastic

Fuse Links NV/NH gG Dimensions

Type	Dimensions												
	A	B	C	D	E	F	G	H	I	J	K		
NV00C	79	53	47	35	15	21	52	7,5				6	kombi
NV00C I	79	53	47	35	15	21	52	7,5				6	kombi
NV00	79	53	47	35	15	28	56	12				6	kombi
NV00 I	79	53	47	35	15	28	56	12				6	kombi
NV0	125	68	65	35	15	28	56	12				6	kombi
NV1C	135	68	65	40	15	28	61	12				6	kombi
NV1C I	135	68	65	40	15	28	61	12				6	kombi
NV1	135	72	65	40	20	46	65	14				6	kombi
NV1 I	135	72	65	40	20	46	65	14				6	kombi
NV2C	150	72	65	48	20	46	73	14				6	kombi
NV2C I	150	72	65	48	20	46	73	14				6	kombi
NV2	150	72	65	48	26	54	73	14				6	kombi
NV2 I	150	72	65	48	26	54	73	14				6	kombi
NV3C	150	72	65	60	26	54	84	14				6	kombi
NV3	150	72	65	60	33	65	84	14				6	kombi
NV4	200	75	66	87	50	100	121	24	150	16		8	
NV4a	200	99	87	85	50	95	121	27				6	
NV4a SI*	200	99	87	85	50	95	121	27				6	

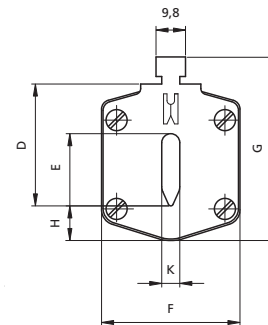
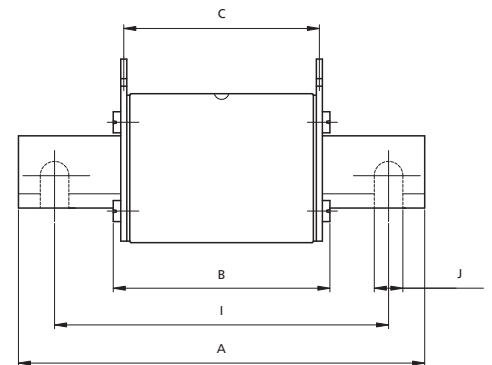

Fuse Links NV/NH gG with Striker Pin Dimensions

Type	Dimensions			
	K	L	M	S1
00C	0	20.7	16.7	7.5
00	0	20.7	16.7	7.5
1	13.7	19.7	25	12
2	16.2	27.4	25	12
3	17	35.6	25	12
4a	24	49	25	12

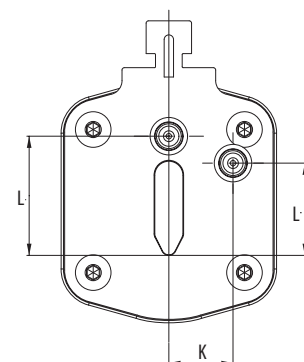
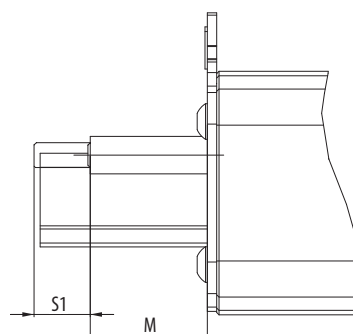

Fuse-link NV/NH gG characteristics

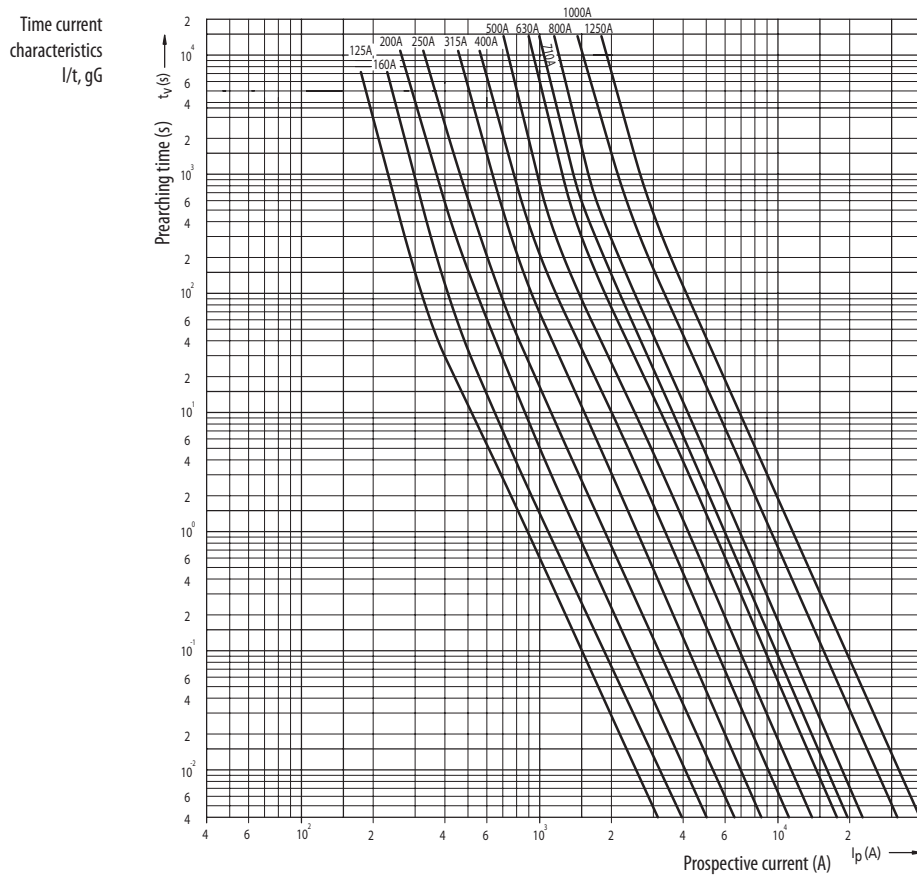
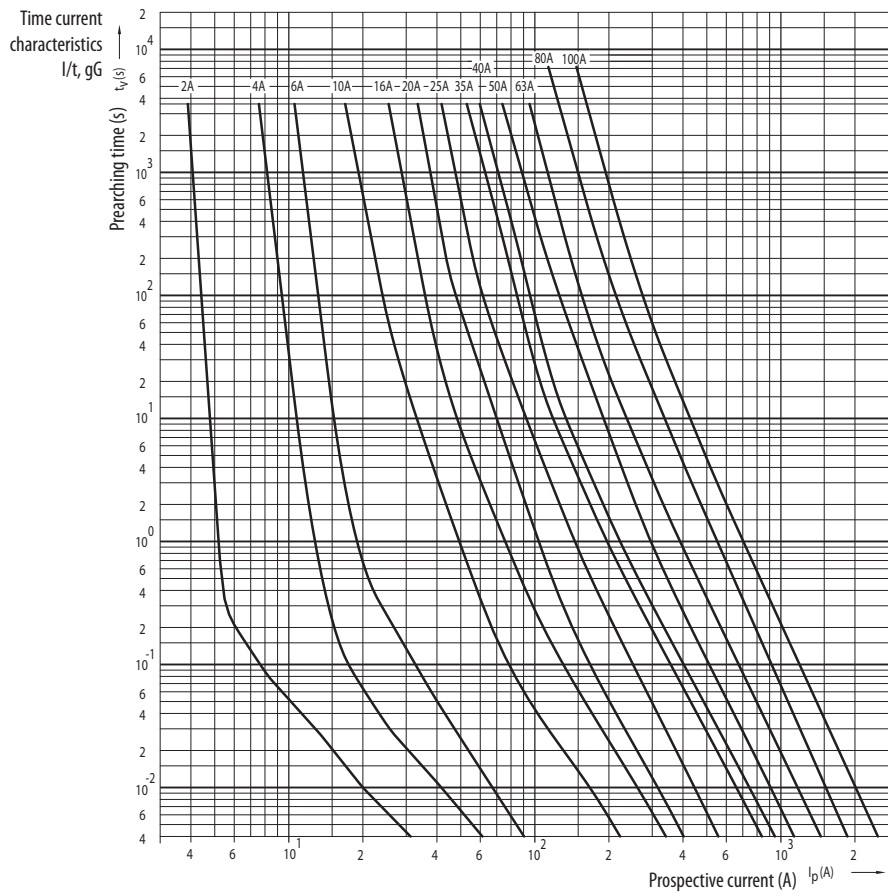

Technical data

Time current characteristics I/t, gG (nonstandard rated currents)

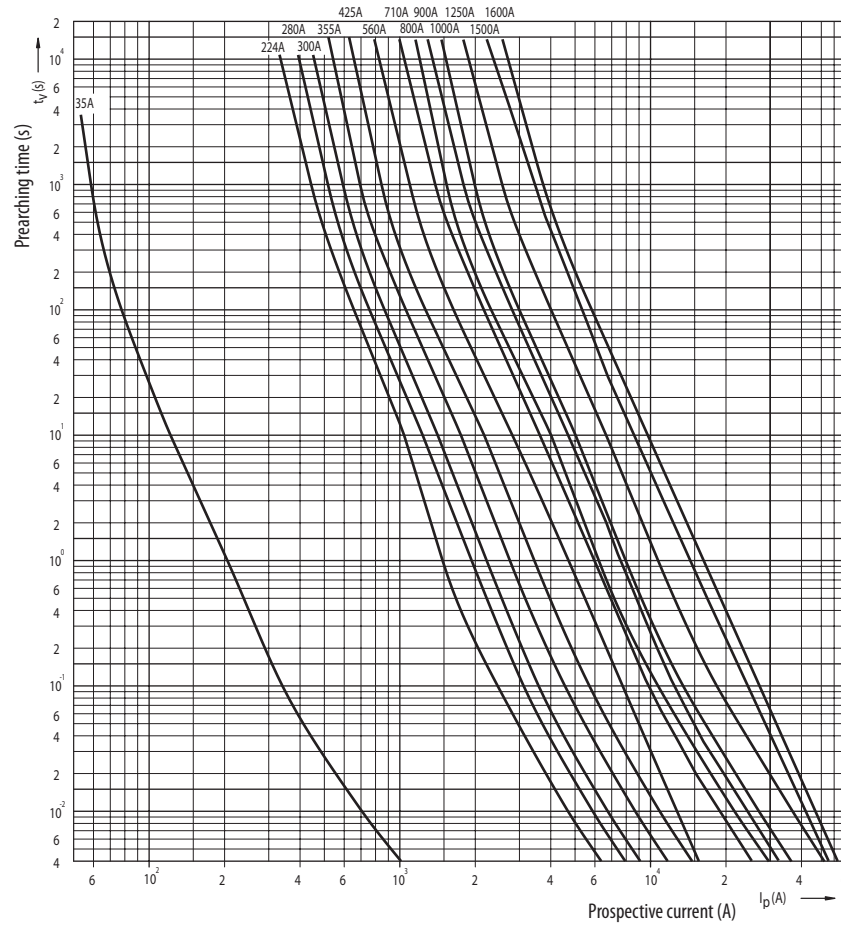

Cut-off current characteristics

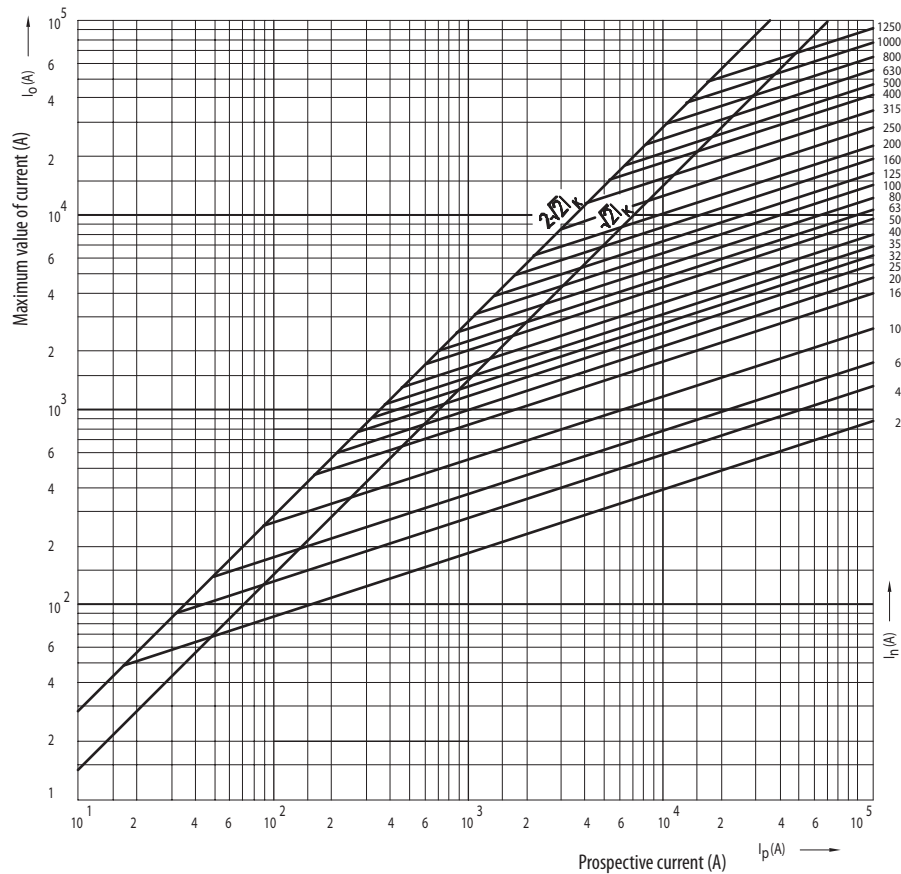

NV fuse-link aM

Time current characteristics
I/t, aM

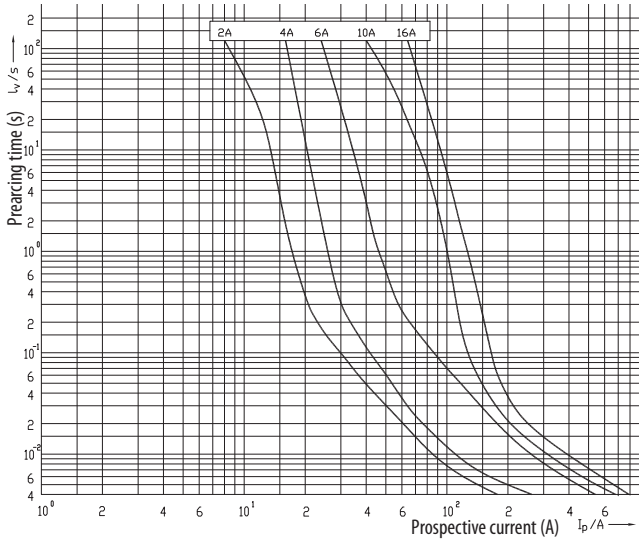

Technical data:

Rated voltage U_n	690 V AC
Rated current I_n	2-1250 A
Dimensions	DIN 43620, IEC 60269, EN 60269
Fusing characteristics	aM -> VDE 0636-2011, DIN VDE 0636
Breaking capacity at $1,1 U_n$	100 kA

Power dissipation of fuse-links NV aM 690 V a.c.

size	the highest rated current at according to VDE 0636-2011 690 V AC (A)	the maximal power dissipation 690 V AC (W)	real power dissipation of fuse-links 690 V AC (W)
NV 00	160	12	9
NV 1	250	32	28
NV 2	400	45	41
NV 3	630	60	58
NV 4a	1250	105	110

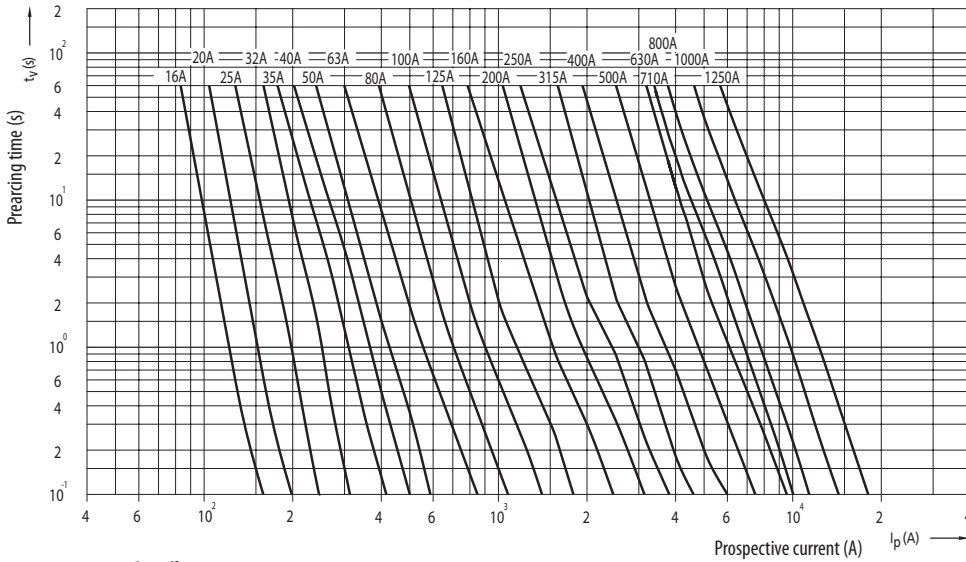

Cut-off current characteristics

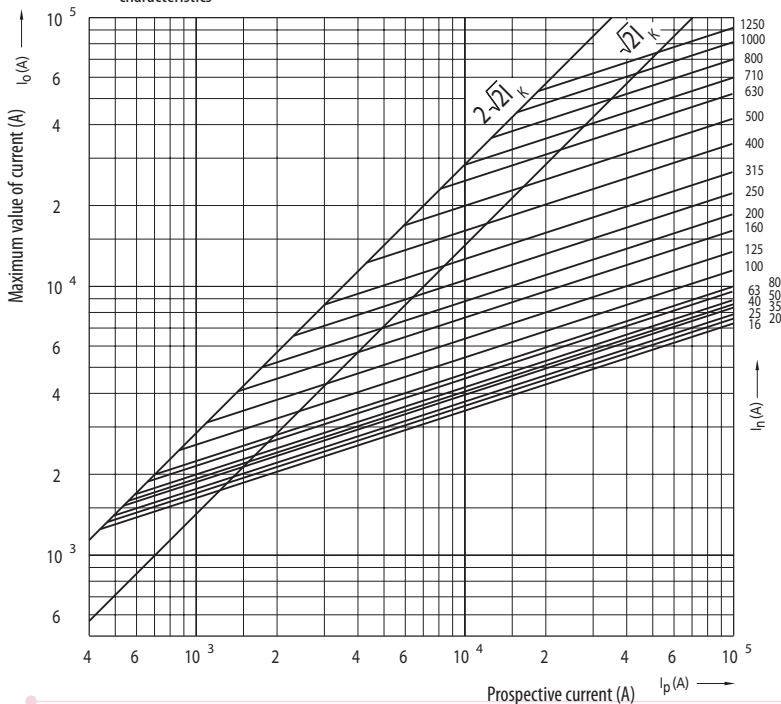

NV/NH

Technical data

Fuse-link NV/NH gF

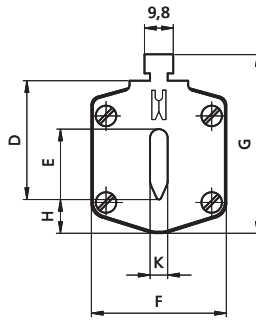
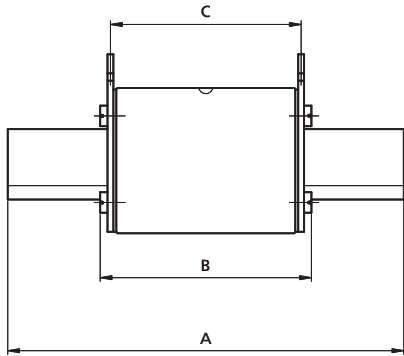

Technical data:	
Rated voltage U_n	400 V AC
Rated current I_n	20 - 250 A
Dimensions	DIN 43620, IEC 60269, EN 60269
Fusing characteristics	gF -> PN 91/E-06160/10 PN 91/E-06160/21
Breaking capacity I_n	100kA

type	dimensions											
	A	B	C	D	E	F	G	H	I	J	K	
NV00C	79	53	47	35	15	21	52	7,5				6
NV00	79	53	47	35	15	28	56	12				6
NV1C	135	68	65	40	15	28	61	12				6
NV1	135	72	65	40	20	46	65	14				6

Power dissipation of fuse-links gF 400 V a.c.

size	the highest rated current at according to PN-IEC 60269-2 (A)	the maximal power dissipation (W)	real power dissipation of fuse-links (W)
NV 00C	100	12	7,2
NV 00	160	16	15,1
NV 1C	160	23	21,9
NV 1	250	32	31,3

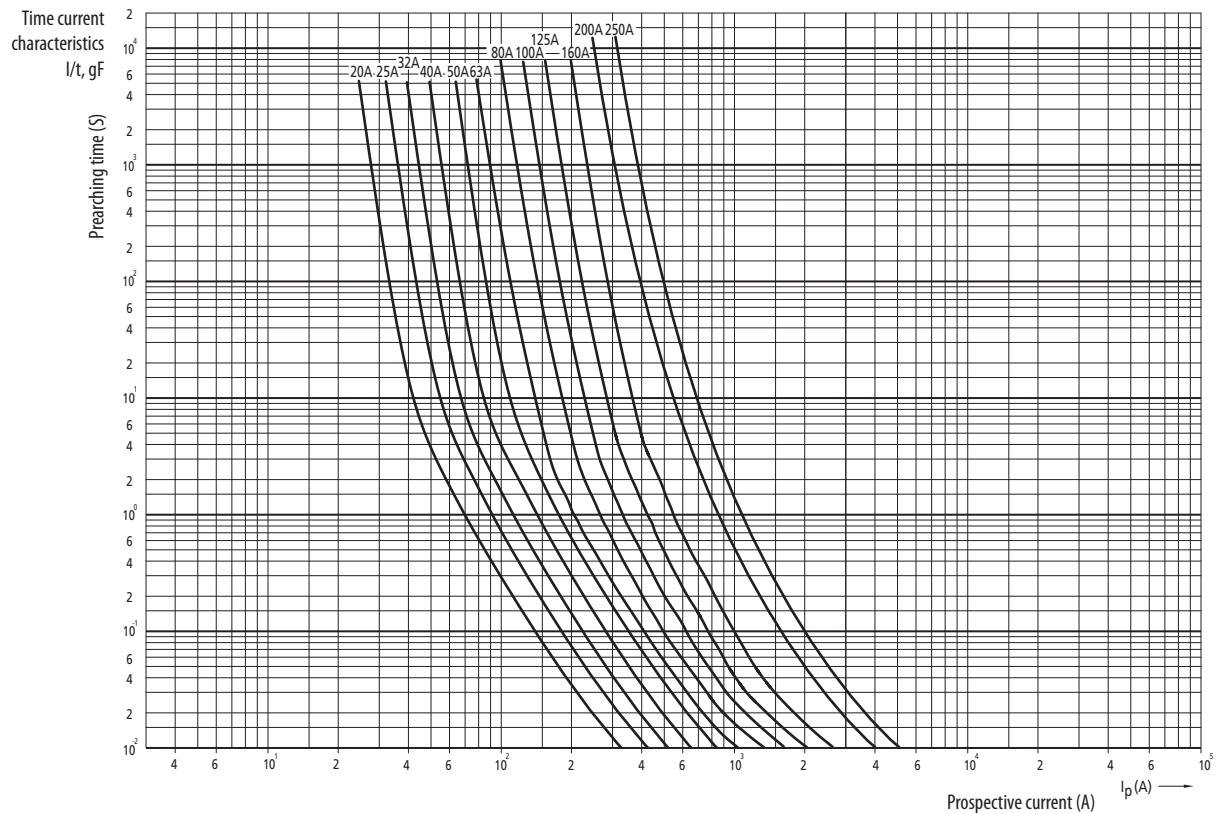

Fuse-link NV/NH gTr

Technical data:

Rated voltage	400 V AC
Rated transformer power	50-1000 kVA
Breaking capacity	100 kA

Time current characteristics
I/t, gTr

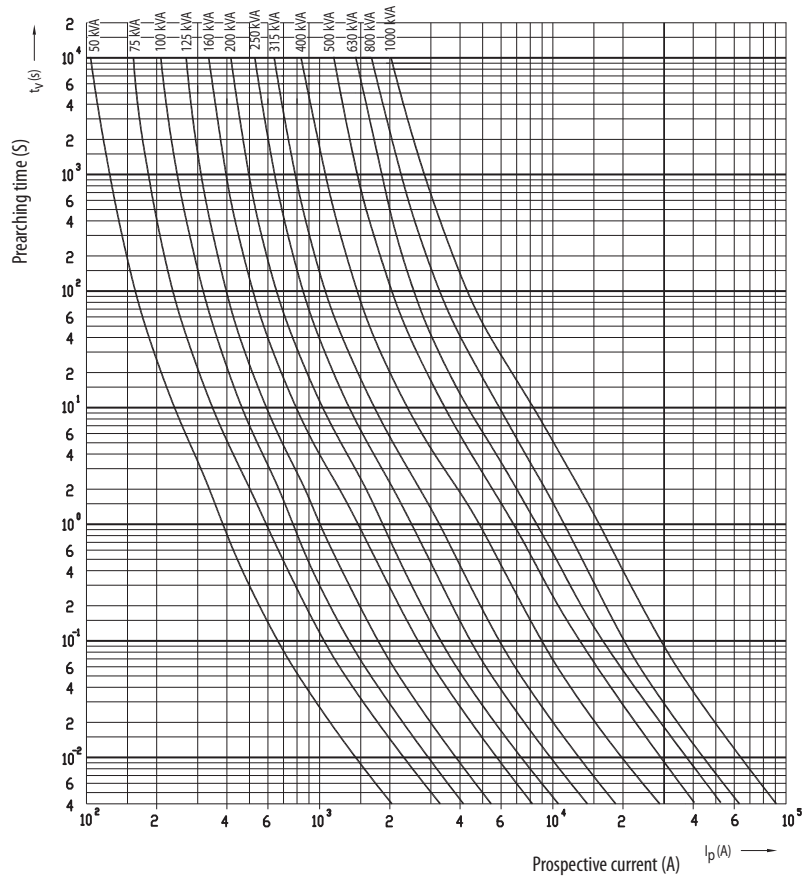

PK Fuse Bases with Ceramic Insulation sizes 00 to 3

Technical data			00	1	2	3		
Electrical characteristics								
Rated voltage	U_n	V a.c.	690					
Rated current	I_n	A	160	250	400	630		
Conv. free air thermal current with fuse links	I_{th}	A	160	250	400	630		
Conv. free air thermal current with solid links	I_{th}	A	200	320	500	800		
Rated frequency		Hz	40-60					
Max. permis. power dissipation per fuse link	P_a	W	12	32	45	60		
Max. breaking capacity per fuse link	I_{cu}	kA	200					
			≤ 35	$^{\circ}C$	1			
			40	$^{\circ}C$	0,95			
Derating temperature factors for max. current	50	$^{\circ}C$	0,85					
	Mechanical characteristics							
Ambient temperature range	T_{amb}	$^{\circ}C$	-25...+55					
Rated operating mode			uninterrupted					
Mounting position			vertical, horizontal					
Pollution degree			3					
Overvoltage category			III					
Degree of protection			IP00 without covers; IP20 with covers fitted					
Standards			IEC 60269-2, DIN VDE 0636, DIN 43620					

Technical data

Dimensions for size 00

1p	3p	E	F	L	P	R	S*	T*
PK 00 M8-M8 1p S	PK 00 M8-M8 3p S	M8-M8	Ø 7,5	\	\	\	88	126
PK 00 2M6-2M6 1p S	PK 00 2M6-2M6 3p S	2M6-2M6	Ø 7,5	\	\	\	88	126
PK 00 M8-2M6 1p S	PK 00 M8-2M6 3p S	M8-2M6	Ø 7,5	\	\	\	88	126
PK 00 M8-P00 1p S	PK 00 M8-P00 3p S	M8-P00	Ø 7,5	\	\	\	88	126
PK 00 M8-2P00 1p S	PK 00 M8-2P00 3p S	M8-2P00	Ø 7,5	\	\	\	88	126
PK 00 P00-P00 1p S	PK 00 P00-P00 3p S	P00-P00	Ø 7,5	\	\	\	88	126
PK 00 P00-2P00 1p S	PK 00 P00-2P00 3p S	P00-2P00	Ø 7,5	\	\	\	88	126
PK 00 2P00-2P00 1p S	PK 00 2P00-2P00 3p S	2P00-2P00	Ø 7,5	\	\	\	88	126
PKI 00 M8-M8 1p S	PKI 00 M8-M8 3p S	M8-M8	Ø 7,5	87	140	\	\	\
PKI 00 2M6-2M6 1p S	PKI 00 2M6-2M6 3p S	2M6-2M6	Ø 7,5	87	140	\	\	\
PKI 00 M8-2M6 1p S	PKI 00 M8-2M6 3p S	M8-2M6	Ø 7,5	87	140	\	\	\
PKI 00 M8-P00 1p S	PKI 00 M8-P00 3p S	M8-P00	Ø 7,5	87	140	\	\	\
PKI 00 M8-2P00 1p S	PKI 00 M8-2P00 3p S	M8-2P00	Ø 7,5	87	140	\	\	\
PKI 00 P00-P00 1p S	PKI 00 P00-P00 3p S	P00-P00	Ø 7,5	87	140	\	\	\
PKI 00 P00-2P00 1p S	PKI 00 P00-2P00 3p S	P00-2P00	Ø 7,5	87	140	\	\	\
PKI 00 2P00-2P00 1p S	PKI 00 2P00-2P00 3p S	2P00-2P00	Ø 7,5	87	140	\	\	\
PKIP 00 M8-M8 1p S	PKIP 00 M8-M8 3p S	M8-M8	Ø 7,5	87	140	95	\	\
PKIP 00 2M6-2M6 1p S	PKIP 00 2M6-2M6 3p S	2M6-2M6	Ø 7,5	87	140	95	\	\
PKIP 00 M8-2M6 1p S	PKIP 00 M8-2M6 3p S	M8-2M6	Ø 7,5	87	140	95	\	\
PKIP 00 M8-P00 1p S	PKIP 00 M8-P00 3p S	M8-P00	Ø 7,5	87	140	95	\	\
PKIP 00 M8-2P00 1p S	PKIP 00 M8-2P00 3p S	M8-2P00	Ø 7,5	87	140	95	\	\
PKIP 00 P00-P00 1p S	PKIP 00 P00-P00 3p S	P00-P00	Ø 7,5	87	140	95	\	\
PKIP 00 P00-2P00 1p S	PKIP 00 P00-2P00 3p S	P00-2P00	Ø 7,5	87	140	95	\	\
PKIP 00 2P00-2P00 1p S	PKIP 00 2P00-2P00 3p S	2P00-2P00	Ø 7,5	87	140	95	\	\

*Protective barriers; included with PK 00 3p fuse bases or sold separately

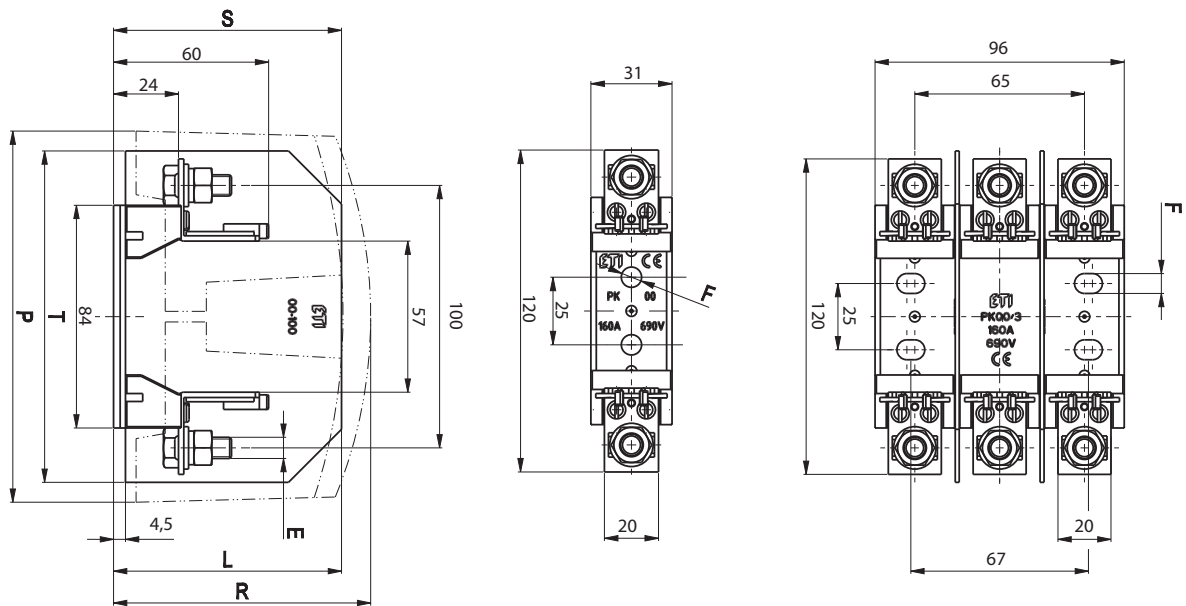

Dimensions for sizes 1, 2, 3

1p	3p	A	C	D	E	H - 1p	H - 3p	K	L**	P**	R**	S*	T*	U
PK 1 M10-M10 1p S	PK 1 M10-M10 3p S	175	141	82	M10-M10	55,5	160	200	108	245	113	108	245	106
PK 1 M10-S12 1p S	PK 1 M10-S12 3p S	175	141	82	M10-S12	55,5	160	200	108	245	113	108	245	106
PK 1 S12-S12 1p S	PK 1 S12-S12 3p S	175	141	82	S12-S12	55,5	160	200	108	245	113	108	245	106
PK 1 M10-P1 1p S	PK 1 M10-P1 3p S	175	141	82	M10-P1	55,5	160	200	108	245	113	108	245	106
PK 1 M10-2P1 1p S	PK 1 M10-2P1 3p S	175	141	82	M10-2P1	55,5	160	200	108	245	113	108	245	106
PK 1 P1-P1 1p S	PK 1 P1-P1 3p S	175	141	82	P1-P1	55,5	160	200	108	245	113	108	245	106
PK 1 P1-2P1 1p S	PK 1 P1-2P1 3p S	175	141	82	P1-2P1	55,5	160	200	108	245	113	108	245	106
PK 1 2P1-2P1 1p S	PK 1 2P1-2P1 3p S	175	141	82	2P1-2P1	55,5	160	200	108	245	113	108	245	106
PK 2 M10-M10 1p S	PK 2 M10-M10 3p S	200	166	87	M10-M10	65	185	225	115	266	125	117	266	125
PK 2 M10-S12 1p S	PK 2 M10-S12 3p S	200	166	87	M10-S12	65	185	225	115	266	125	117	266	125
PK 2 S12-S12 1p S	PK 2 S12-S12 3p S	200	166	87	S12-S12	65	185	225	115	266	125	117	266	125
PK 2 M10-P2 1p S	PK 2 M10-P2 3p S	200	166	87	M10-P2	65	185	225	115	266	125	117	266	125
PK 2 M10-2P2 1p S	PK 2 M10-2P2 3p S	200	166	87	M10-2P2	65	185	225	115	266	125	117	266	125
PK 2 P2-P2 1p S	PK 2 P2-P2 3p S	200	166	87	P2-P2	65	185	225	115	266	125	117	266	125
PK 2 P2-2P2 1p S	PK 2 P2-2P2 3p S	200	166	87	P2-2P2	65	185	225	115	266	125	117	266	125
PK 2 2P2-2P2 1p S	PK 2 2P2-2P2 3p S	200	166	87	2P2-2P2	65	185	225	115	266	125	117	266	125
PK 3 M12-M12 1p S	PK 3 M12-M12 3p S	210	166	99	M12-M12	65	208	240	127	266	135	130	266	148
PK 3 M12-P3 1p S	PK 3 M12-P3 3p S	210	166	99	M12-P3	65	208	240	127	266	135	130	266	148
PK 3 M12-2P3 1p S	PK 3 M12-2P3 3p S	210	166	99	M12-2P3	65	208	240	127	266	135	130	266	148
PK 3 P3-P3 1p S	PK 3 P3-P3 3p S	210	166	99	P3-P3	65	208	240	127	266	135	130	266	148
PK 3 P3-2P3 1p S	PK 3 P3-2P3 3p S	210	166	99	P3-2P3	65	208	240	127	266	135	130	266	148
PK 3 2P3-2P3 1p S	PK 3 2P3-2P3 3p S	210	166	99	2P3-2P3	65	208	240	127	266	135	130	266	148

*Protective barriers; included with 3p fuse bases or sold separately

**Terminal covers and fuse covers; sold separately

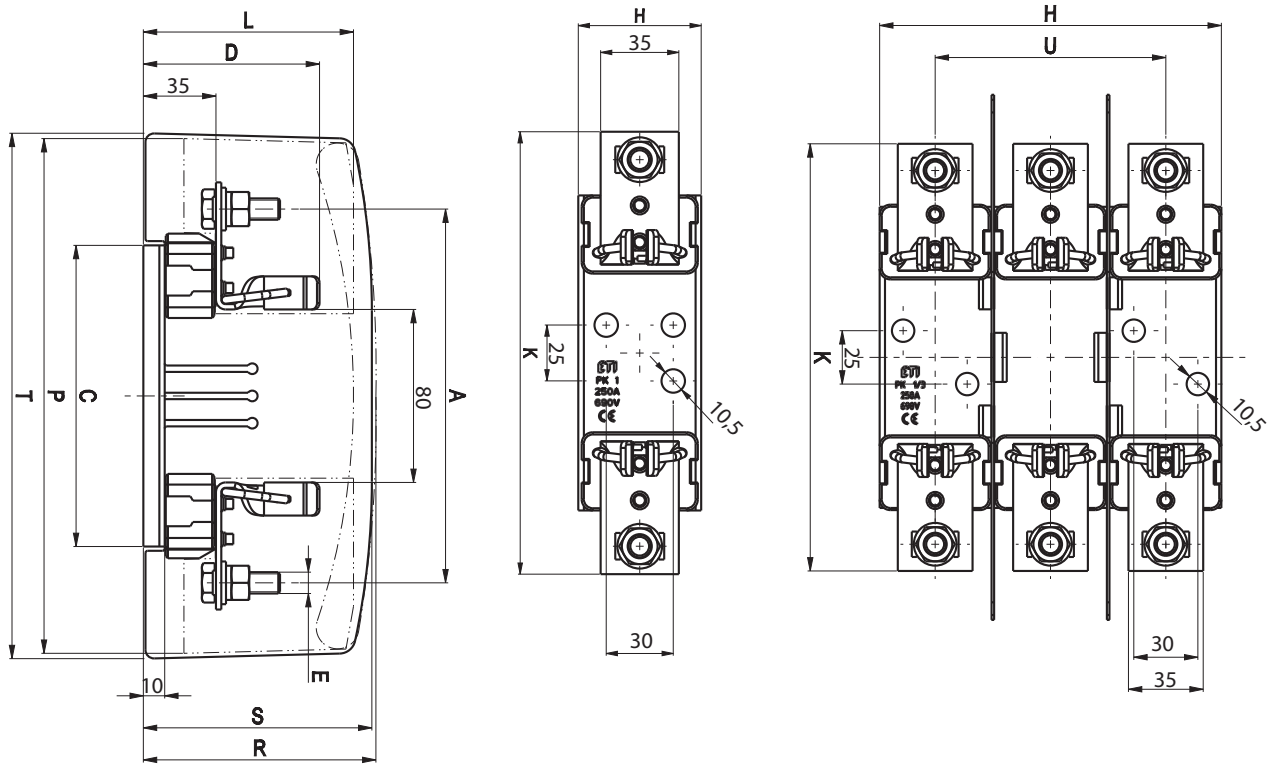

Technical data

Type of connections

	a	b	c	d	e _{max}	Tightening torque [Nm]	Connections [mm ²]
P00	24	15	15	M5	25	2,6	10-70 Cu/Al
2P00	24	15	15	M5	35	2,6	2x(10-50) Cu/Al
P1	37	20	25	M6	30	4,5	70-150 Cu/Al
2P1	37	20	25	M6	42	4,5	2x(70-95) Cu/Al
P2	42	22	28	M8	40	11	120-240 Cu/Al
2P2	42	22	28	M8	55	11	2x(120-150) Cu/Al
P3	50	25	30	M8	44	11	120-300 Cu/Al
2P3	50	25	30	M8	66	11	2x(120-240) Cu/Al
2xM6	26	15	14	M6	16	4	6-70 Cu
S12	36	16	25	M6	25	9,5	25-150Cu
M8				M8	20	10	
M10				M10	30	32	
M12				M12	30	32	
V shaped clamp	35	23	58		45	22	SM: 50-240 Cu/Al SE: 300 Cu/Al RM: 37-70 Cu/Al RE: 25-50 Cu/Al

P00, P1, P2, P3

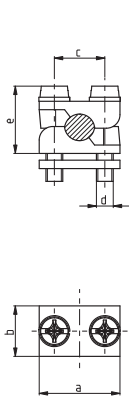

2P00, 2P1, 2P2, 2P3

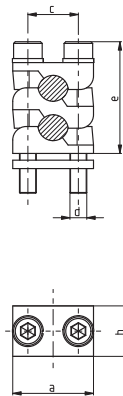

2xM6, S12

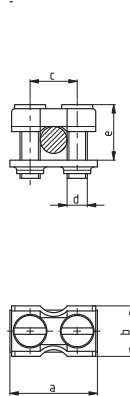

M8, M10, M12

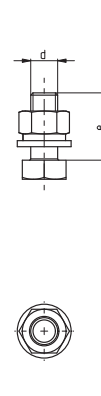

V shaped clamp

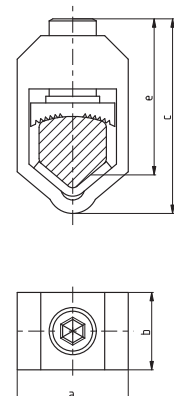

Technical data for Neutral Terminal Base / Earth Clamp

Size	00	1	2	3
Electrical characteristics				
Rated voltage	U _n	V a.c.	690	
Rated current	I _n	A	160	250 400 630
Cable terminal				
Connection		M8-2M5	M10-M10	M12-M12
Tightening torque		Nm	10-2,6	32

Dimensions for Neutral Terminal Base / Earth Clamp

[mm]	A	B	C	D	E	F	G	H	I	J
PK 00/0 M8-2M5 S	100	84	4,5	26,5	Ø 7,5	25	\	31	20	115
PK 1 M10-M10 S	175	141	10	38	Ø 10,5	25	30	55,5	26	200
PK 2 M10-M10 S	200	166	10	40	Ø 10,5	25	30	65	30	225
PK 3 M12-M12 S	210	166	10	40	Ø 10,5	25	30	65	30	240

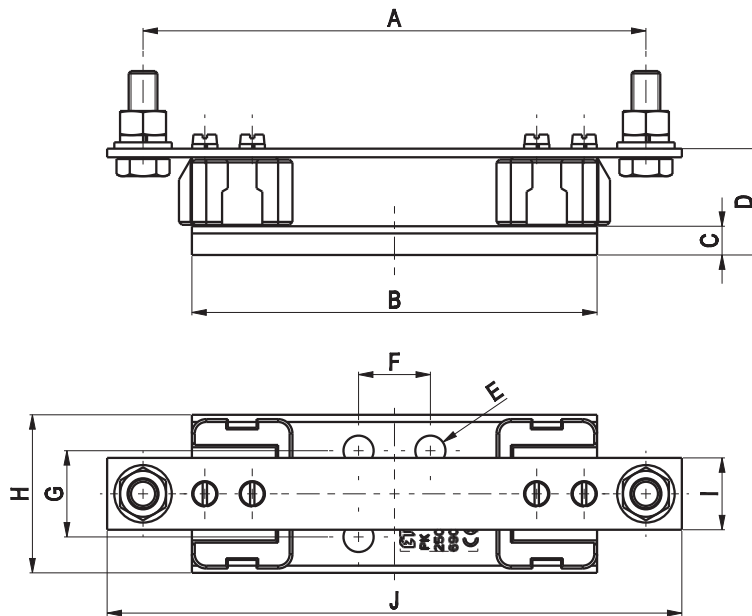

Plastic fuse bases type PT size 00 to 3

Technical data

Size	00	1	2	3		
Electrical characteristics						
Rated voltage	U_n	V a.c.	690			
Rated current	I_n	A	160	250	400	630
Conv. free air thermal current with fuse links	I_{th}	A	160	250	400	630
Conv. free air thermal current with solid links	I_{th}	A	200	320	500	800
Rated frequency		Hz	40-60			
Max. permis. power dissipation per fuse link	P_n	W	12	32	45	60
Max. breaking capacity per fuse link	I_{cu}	kA	120			
Derating temperature factors for max. current	≤ 35	°C	1			
	40	°C	0,95			
	50	°C	0,85			
Mechanical characteristics						
Ambient temperature range	T_{amb}	°C	-25...+55			
Rated operating mode			uninterrupted			
Mounting position			vertical, horizontal			
Pollution degree			3			
Overvoltage category			III			
Degree of protection			IP00 without covers; IP20 with covers fitted			
Standards			IEC 60269-2, DIN VDE 0636, DIN 43620			

Technical data

Dimensions for size 00

1p	3p	E	F	L	P	R	S*	T*
PT 00 M8-M8 1p	PT 00 M8-M8 3p	M8-M8	Ø7,5	\	\	\	86	140
PT 00 2M6-2M6 1p	PT 00 2M6-2M6 3p	2M6-2M6	Ø7,5	\	\	\	86	140
PT 00 M8-2M6 1p	PT 00 M8-2M6 3p	M8-2M6	Ø7,5	\	\	\	86	140
PT 00 M8-P00 1p	PT 00 M8-P00 3p	M8-P00	Ø7,5	\	\	\	86	140
PT 00 M8-2P00 1p	PT 00 M8-2P00 3p	M8-2P00	Ø7,5	\	\	\	86	140
PT 00 P00-P00 1p	PT 00 P00-P00 3p	P00-P00	Ø7,5	\	\	\	86	140
PT 00 P00-2P00 1p	PT 00 P00-2P00 3p	P00-2P00	Ø7,5	\	\	\	86	140
PT 00 2P00-2P00 1p	PT 00 2P00-2P00 3p	2P00-2P00	Ø7,5	\	\	\	86	140
<hr/>								
PTI 00 M8-M8 1p	PTI 00 M8-M8 3p	M8-M8	Ø7,5	87	140	\	\	\
PTI 00 2M6-2M6 1p	PTI 00 2M6-2M6 3p	2M6-2M6	Ø7,5	87	140	\	\	\
PTI 00 M8-2M6 1p	PTI 00 M8-2M6 3p	M8-2M6	Ø7,5	87	140	\	\	\
PTI 00 M8-P00 1p	PTI 00 M8-P00 3p	M8-P00	Ø7,5	87	140	\	\	\
PTI 00 M8-2P00 1p	PTI 00 M8-2P00 3p	M8-2P00	Ø7,5	87	140	\	\	\
PTI 00 P00-P00 1p	PTI 00 P00-P00 3p	P00-P00	Ø7,5	87	140	\	\	\
PTI 00 P00-2P00 1p	PTI 00 P00-2P00 3p	P00-2P00	Ø7,5	87	140	\	\	\
PTI 00 2P00-2P00 1p	PTI 00 2P00-2P00 3p	2P00-2P00	Ø7,5	87	140	\	\	\
<hr/>								
PTIP 00 M8-M8 1p	PTIP 00 M8-M8 3p	M8-M8	Ø7,5	87	140	95	\	\
PTIP 00 2M6-2M6 1p	PTIP 00 2M6-2M6 3p	2M6-2M6	Ø7,5	87	140	95	\	\
PTIP 00 M8-2M6 1p	PTIP 00 M8-2M6 3p	M8-2M6	Ø7,5	87	140	95	\	\
PTIP 00 M8-P00 1p	PTIP 00 M8-P00 3p	M8-P00	Ø7,5	87	140	95	\	\
PTIP 00 M8-2P00 1p	PTIP 00 M8-2P00 3p	M8-2P00	Ø7,5	87	140	95	\	\
PTIP 00 P00-P00 1p	PTIP 00 P00-P00 3p	P00-P00	Ø7,5	87	140	95	\	\
PTIP 00 P00-2P00 1p	PTIP 00 P00-2P00 3p	P00-2P00	Ø7,5	87	140	95	\	\
PTIP 00 2P00-2P00 1p	PTIP 00 2P00-2P00 3p	2P00-2P00	Ø7,5	87	140	95	\	\

*Protective barriers

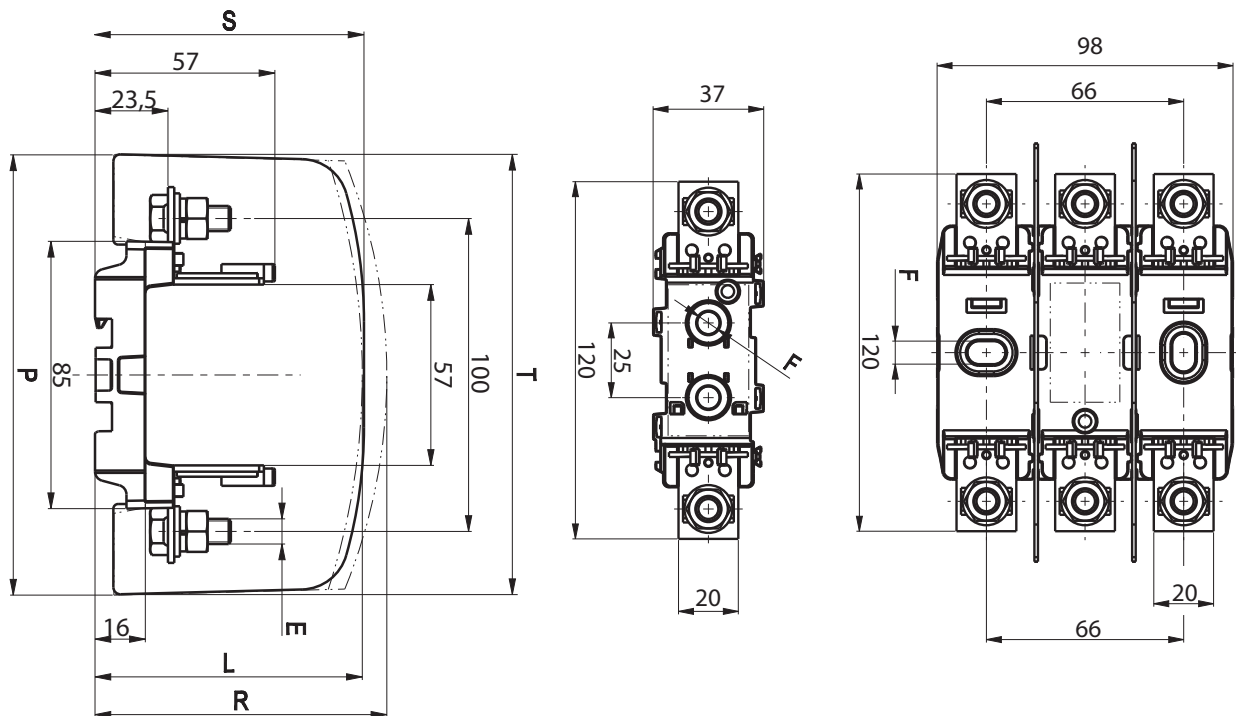

Dimensions for sizes 1, 2, 3

1p	3p	A	D	E	F	H	J	K	L**	P**	R**	S*	T*	U
PT 1 M10-M10 1p	PT 1 M10-M10 3p	175	81	M10-M10	10,5	190	25	200	103	244	110	108	241	130
PT 1 M10-S12 1p	PT 1 M10-S12 3p	175	81	M10-S12	10,5	190	25	200	103	244	110	108	241	130
PT 1 S12-S12 1p	PT 1 S12-S12 3p	175	81	S12-S12	10,5	190	25	200	103	244	110	108	241	130
PT 1 M10-P1 1p	PT 1 M10-P1 3p	175	81	M10-P1	10,5	190	25	200	103	244	110	108	241	130
PT 1 M10-2P1 1p	PT 1 M10-2P1 3p	175	81	M10-2P1	10,5	190	25	200	103	244	110	108	241	130
PT 1 P1-P1 1p	PT 1 P1-P1 3p	175	81	P1-P1	10,5	190	25	200	103	244	110	108	241	130
PT 1 P1-2P1 1p	PT 1 P1-2P1 3p	175	81	P1-2P1	10,5	190	25	200	103	244	110	108	241	130
PT 1 2P1-2P1 1p	PT 1 2P1-2P1 3p	175	81	2P1-2P1	10,5	190	25	200	103	244	110	108	241	130
PT 2 M10-M10 1p	PT 2 M10-M10 3p	200	87	M10-M10	10,5	190	25	225	112	268	120	115,5	266	130
PT 2 M10-S12 1p	PT 2 M10-S12 3p	200	87	M10-S12	10,5	190	25	225	112	268	120	115,5	266	130
PT 2 S12-S12 1p	PT 2 S12-S12 3p	200	87	S12-S12	10,5	190	25	225	112	268	120	115,5	266	130
PT 2 M10-P2 1p	PT 2 M10-P2 3p	200	87	M10-P2	10,5	190	25	225	112	268	120	115,5	266	130
PT 2 M10-2P2 1p	PT 2 M10-2P2 3p	200	87	M10-2P2	10,5	190	25	225	112	268	120	115,5	266	130
PT 2 P2-P2 1p	PT 2 P2-P2 3p	200	87	P2-P2	10,5	190	25	225	112	268	120	115,5	266	130
PT 2 P2-2P2 1p	PT 2 P2-2P2 3p	200	87	P2-2P2	10,5	190	25	225	112	268	120	115,5	266	130
PT 2 2P2-2P2 1p	PT 2 2P2-2P2 3p	200	87	2P2-2P2	10,5	190	25	225	112	268	120	115,5	266	130
PT 3 M12-M12 1p	PT 3 M12-M12 3p	210	98	M12-M12	10,5	222	10	240	126	268	133	130	267	166
PT 3 M12-P3 1p	PT 3 M12-P3 3p	210	98	M12-P3	10,5	222	10	240	126	268	133	130	267	166
PT 3 M12-2P3 1p	PT 3 M12-2P3 3p	210	98	M12-2P3	10,5	222	10	240	126	268	133	130	267	166
PT 3 P3-P3 1p	PT 3 P3-P3 3p	210	98	P3-P3	10,5	222	10	240	126	268	133	130	267	166
PT 3 P3-2P3 1p	PT 3 P3-2P3 3p	210	98	P3-2P3	10,5	222	10	240	126	268	133	130	267	166
PT 3 2P3-2P3 1p	PT 3 2P3-2P3 3p	210	98	2P3-2P3	10,5	222	10	240	126	268	133	130	267	166

*Protective barriers; included with 3p fuse bases or sold separately

**Terminal covers and fuse covers; sold separately

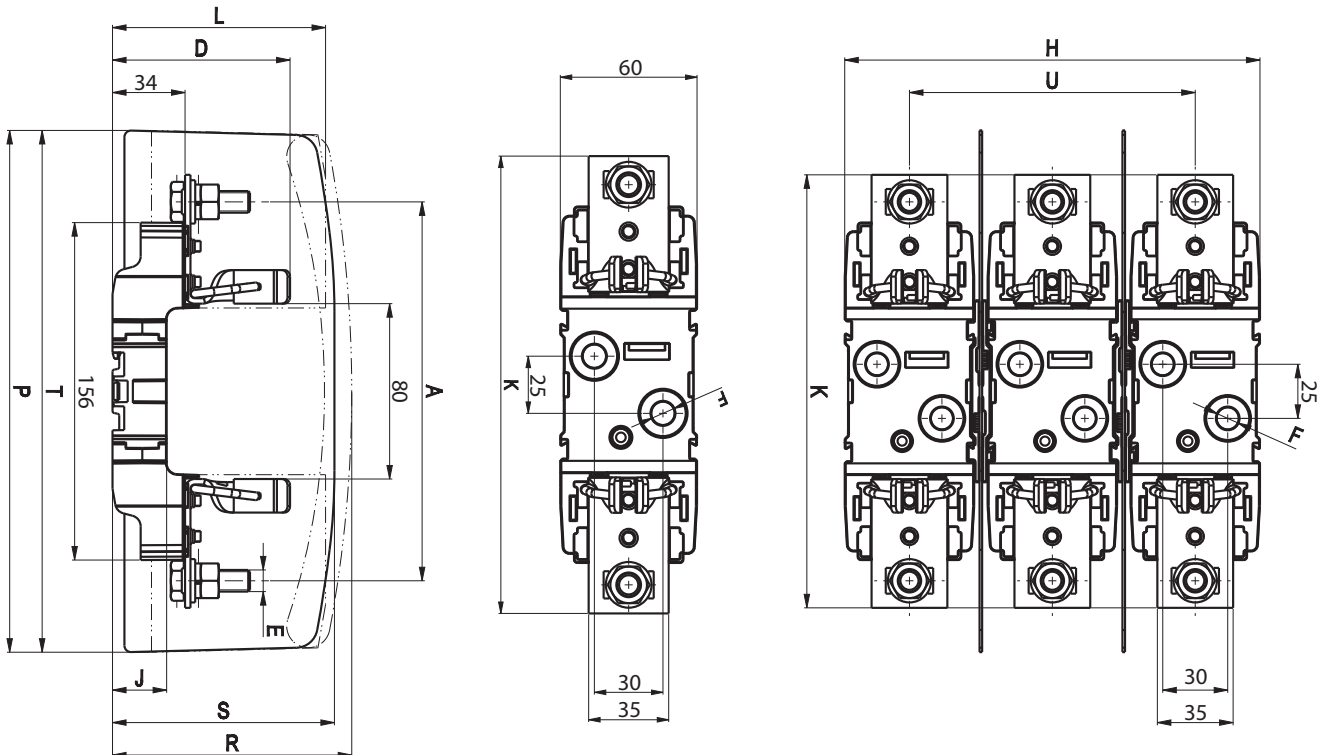

NV/NH

Technical data

Type of connections

	a	b	c	d	e _{max}	Tightening torque [Nm]	Connections [mm ²]
P00	24	15	15	M5	25	2,6	10-70 Cu/Al
2P00	24	15	15	M5	35	2,6	2x(10-50) Cu/Al
P1	37	20	25	M6	30	4,5	70-150 Cu/Al
2P1	37	20	25	M6	42	4,5	2x(70-95) Cu/Al
P2	42	22	28	M8	40	11	120-240 Cu/Al
2P2	42	22	28	M8	55	11	2x(120-150) Cu/Al
P3	50	25	30	M8	44	11	120-300 Cu/Al
2P3	50	25	30	M8	66	11	2x(120-240) Cu/Al
2xM6	26	15	14	M6	16	4	6-70 Cu
S12	36	16	25	M6	25	9,5	25-150Cu
M8				M8	20	10	
M10				M10	30	32	
M12				M12	30	32	
V shaped clamp	35	23	58		45	22	SM: 50-240 Cu/Al SE: 300 Cu/Al RM: 37-70 Cu/Al RE: 25-50 Cu/Al

P00, P1, P2, P3

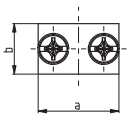
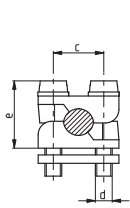

2P00, 2P1, 2P2, 2P3

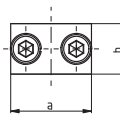
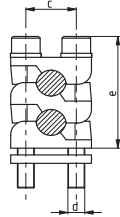

2xM6, S12

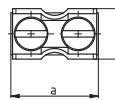
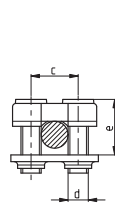

M8, M10, M12

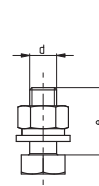

V shaped clamp

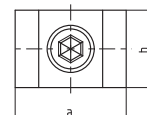
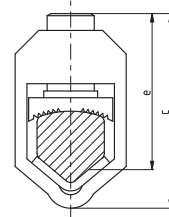

Technical data for Neutral Terminal Base / Earth Clamp

Size	00	1	2	3
Electrical characteristics				
Rated voltage	U _n	V a.c./d.c.	690	
Rated current	I _n	A	160	250 400 630
Cable terminal				
Connection		M8-2M5	M10-M10	M12-M12
Tightening torque		Nm	10-2,6	32

Dimensions for Neutral Terminal Base / Earth Clamp										
[mm]	A	B	C	D	E	F	G	H	I	J
PT 00/0 M8-2M5 S	100	85	4,5	26,5	Ø 7,5	25	\	37	20	115
PT 1 M10-M10 S	175	156	10	38	Ø 10,5	25	30	60	26	200
PT 2 M10-M10 S	200	156	10	40	Ø 10,5	25	30	60	30	225
PT 3 M12-M12 S	210	156	10	40	Ø 10,5	25	30	60	30	240

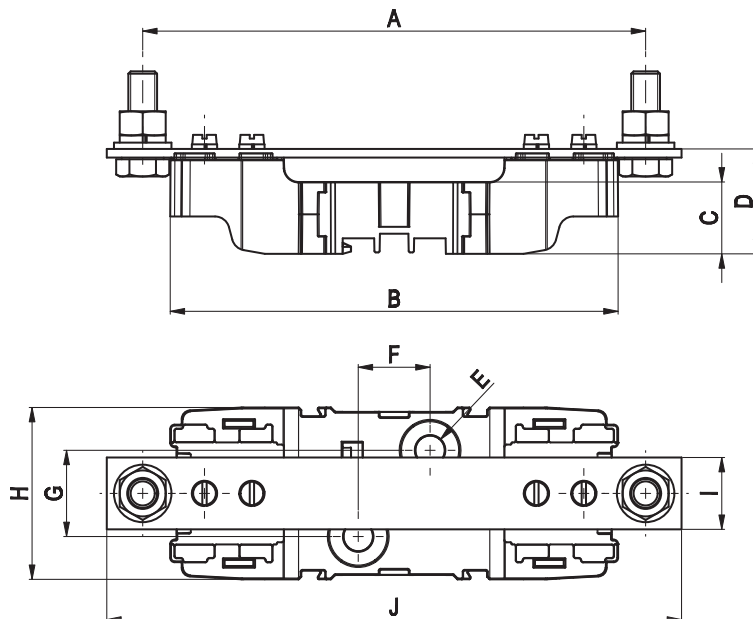

Plastic fuse bases type PLNVV 000 and 00 (fuses with screw connection - S)

Technical data:	
Rated voltage U_n	690 V AC
Rated current I_n	160 A - sizes 00C, 00, 0 250 A - size 1 400 A - size 2 630 A - size 3
Degree of pollution	3 -> IEC 60947, DIN EN 60947, DIN VDE 0110
Standards	IEC 60269, DIN EN 60269, DIN VDE 0636, HRN EN 60269

Dimensions

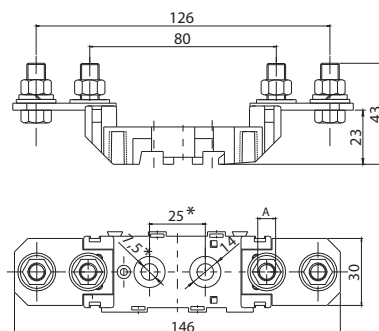

	A
PLNVV -000	M8
PLNVV -00	M10

Technical data

Neutral terminal base PLNS

PLNS - 00 N

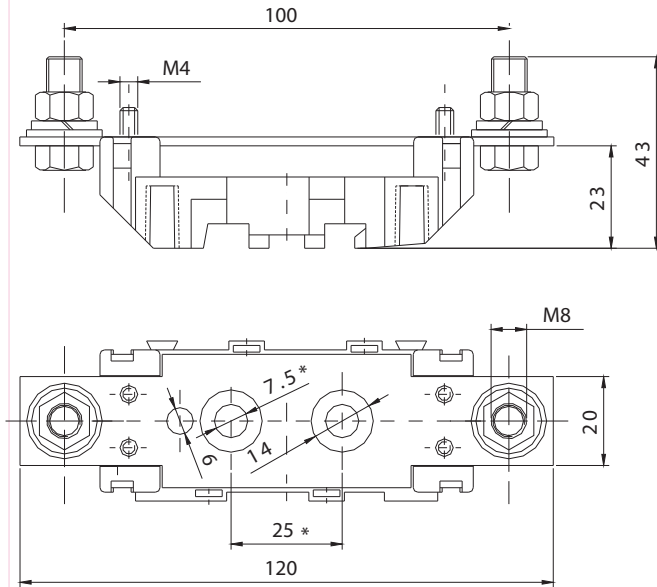

2PLNS - 1,2 N

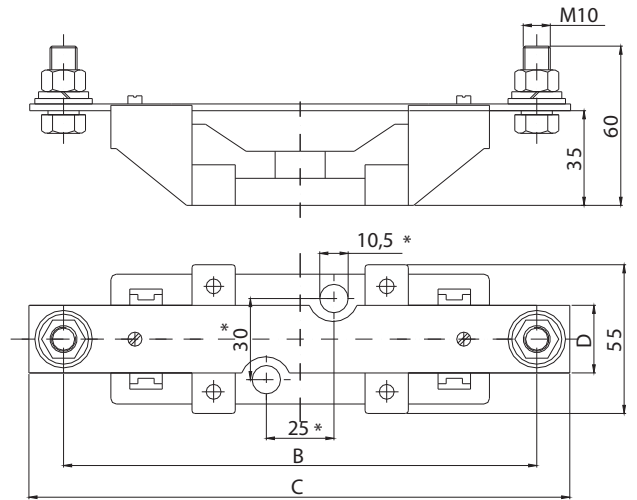

	2PLNS - 1N	2PLNS - 2N
B	175,6	200
C	200	230
D	25	30

OS 00, OS 12

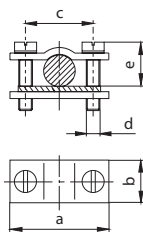

P00, P1, P2, P3

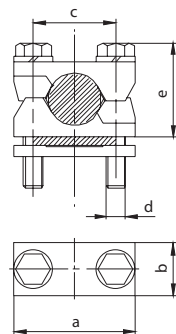

P002, P12, P22, P32

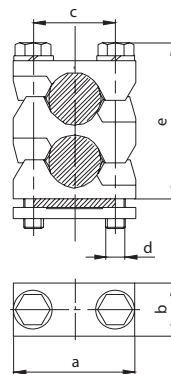

"V" shaped clamp

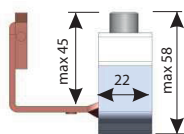

Technical data

Type	a	b	c	d	e _{max}
OS00	24	15	15	M5	15
OS12	36	16	25	M6	25
P00	24	15	15	M5	25
P002	24	15	15	M5	35
P1	37	20	25	M6	30
P12	37	20	25	M6	42
P2	42	22	28	M8	40
P22	42	22	28	M8	55
P3	50	25	30	M8	44
P32	50	25	30	M8	66

Accessories

NV separator - Drawing A

Type	I _N (A)	dimension			
		A	B	C	D
NV L 00	160	77,5	49	15	35
NV L 0	160	125	68	15	35
NV L 1	250	133	68	20	40
NV L 2	400	148	68	26	48
NV L 3	630	148	68 </td <td>33</td> <td>60</td>	33	60

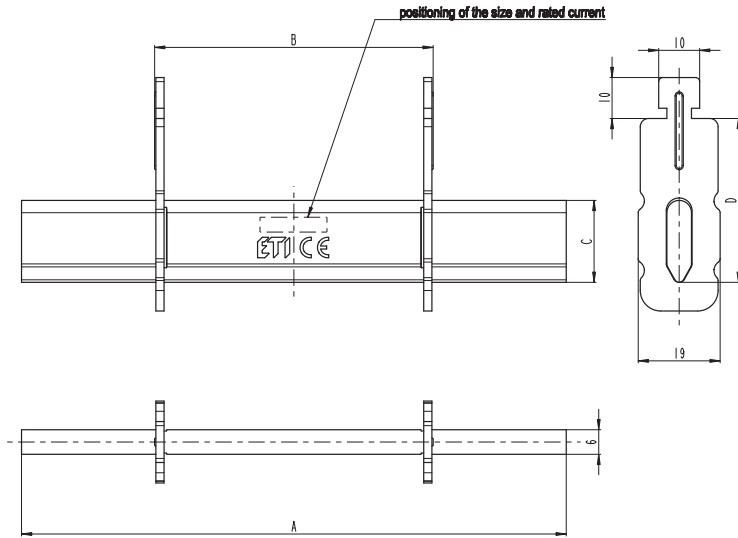

NV separator - Drawing B

type	dimension				
	A	B	C	D	E
NV L 4	68	51	87	200	150
NV L 4a	89	50	86	200	-

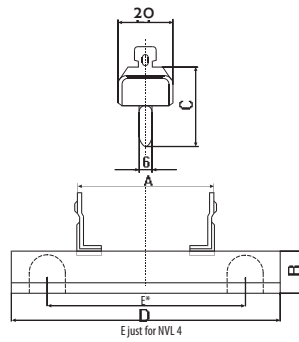

Insulating sleeve of contact spring PK and PP

type	dimension		
	A	B	C
PP 00	32	68	41
PK 1	40	52	33
PK 2	44	63	40
PK 3	44	67	40

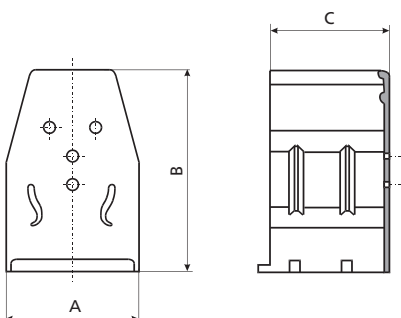

Base separating element

type	dimension	
	A	B
PP 00, PK 00	125	83
PK 0	175	82
PK 1	210	100
PK 2	240	110
PK 3	250	110

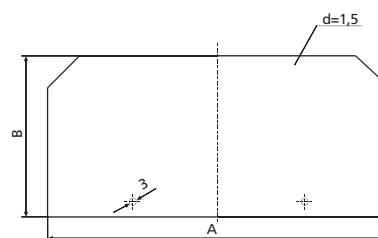

Technical data

NV fuse-rail sizes 00, 1, 2, 3

Technical data of insulated fuse-rails (in accordance with VDE 0636, part 201, IEC 60269-2-1)

Technical Specifications			VL00/100	VL00/185	VL1	VL1H
Electrical Characteristics						
Rated operational voltage	U_e	V	690 AC	690 AC	690 AC	690 AC
Rated operational current	I_e	A	160	160	250	250
Rated frequency	-	Hz	40-60	40-60	40-60	40-60
Rated insulation voltage	U_i	V	800 AC		1000 AC	
Total power loss at I_n (without fuse)	P_v	W	18	23	23	29
Fuse links						
Size - DIN 43 620, IEC 60269-2	-	-	000/00		1	
Max. rated current (gG)	I_n	A	160	160	250	250
Max. permissible power loss per fuse link	P_v	W	12		32	23
Dimensions						
Mass	-	kg	100 mm = 0,8	185mm=1,5	3,5	
Busbars (distance)	-	mm	100	185	185	
Cable connection						
Screw	-	-	M8		M10	
Torque	M_a	Nm	12-15		30-35	
V-clip	-	mm ²	10-95		25-300	25-240 / 25-300
Torque	M_a	Nm	10		32	
Protection						
Operational state	-	-	IP10			
Operating conditions						
Ambient temperature	T_u	°C	-25 ... +55			
Operating condition	-	-	Continuous operation			
Mounting	-	-	vertical, horizontal			
Altitude	-	m	≤ 2000			
Pollution degree	-	-	3			
Overvoltage category	-	-	III	IV		

Technical data of insulated fuse-rails (in accordance with VDE 0636, part 201, IEC 60269-2-1)

Technical Specifications			VL2	VL2H	VL3
Electrical Characteristics					
Rated operational voltage	U_e	V	690 AC	690 AC	690 AC
Rated operational current	I_e	A	400	400	630
Rated frequency	-	Hz	40-60	40-60	40-60
Rated insulation voltage	U_i	V		1000 AC	
Total power loss at I_n (without fuse)	P_v	W	54	73	115
Fuse links					
Size - DIN 43 620, IEC 60269-2	-	-	2		3
Max. rated current (gG)	I_n	A	400	400	630
Max. permissible power loss per fuse link	P_v	W	45	34	48
Dimensions					
Mass	-	kg	3,8		4,3
Busbars (distance)	-	mm	185		
Cable connection					
Screw	-	-	M12	M12	M12
Torque	M_a	Nm	35-40	35-40	35-40
V-clip	-	mm ²	25-300	25-240 / 25-300	25-300
Torque	M_a	Nm	32	32	32
Protection					
Operational state	-	-	IP10		
Operating conditions					
Ambient temperature	T_u	°C	-25 ... +55		
Operating condition	-	-	Continuous operation		
Mounting	-	-	vertical, horizontal		
Altitude	-	m	≤ 2000		
Pollution degree	-	-	3		
Overvoltage category	-	-	IV		

Dimensional overview of LV NV fuse-rails

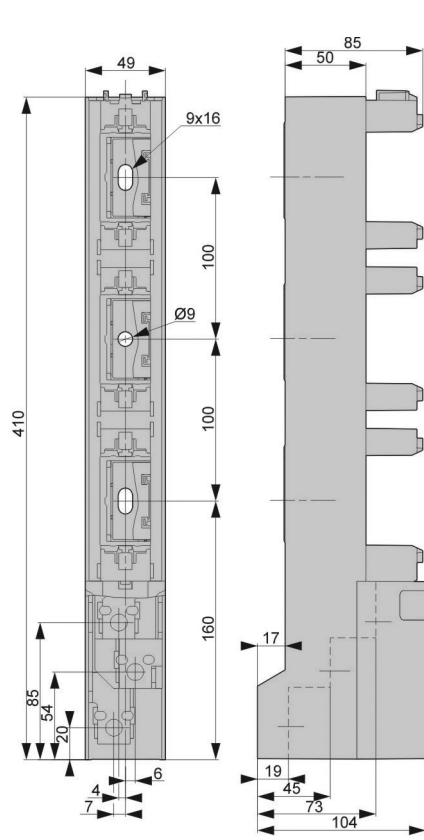

size 00/100

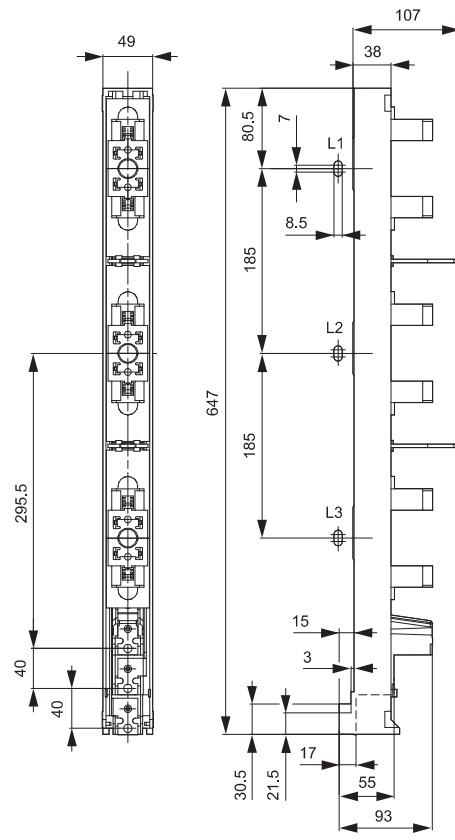

size 00/185

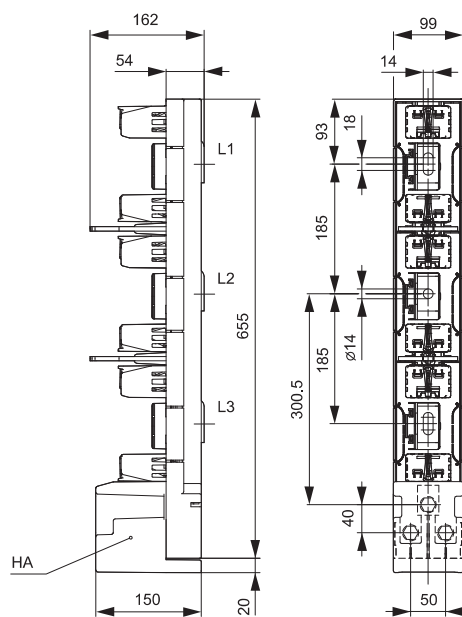
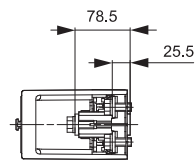
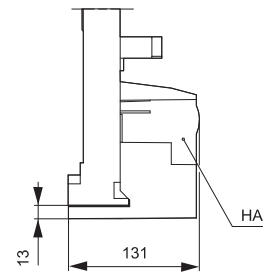

size 1, 2, 3 (M terminal)

Technical data

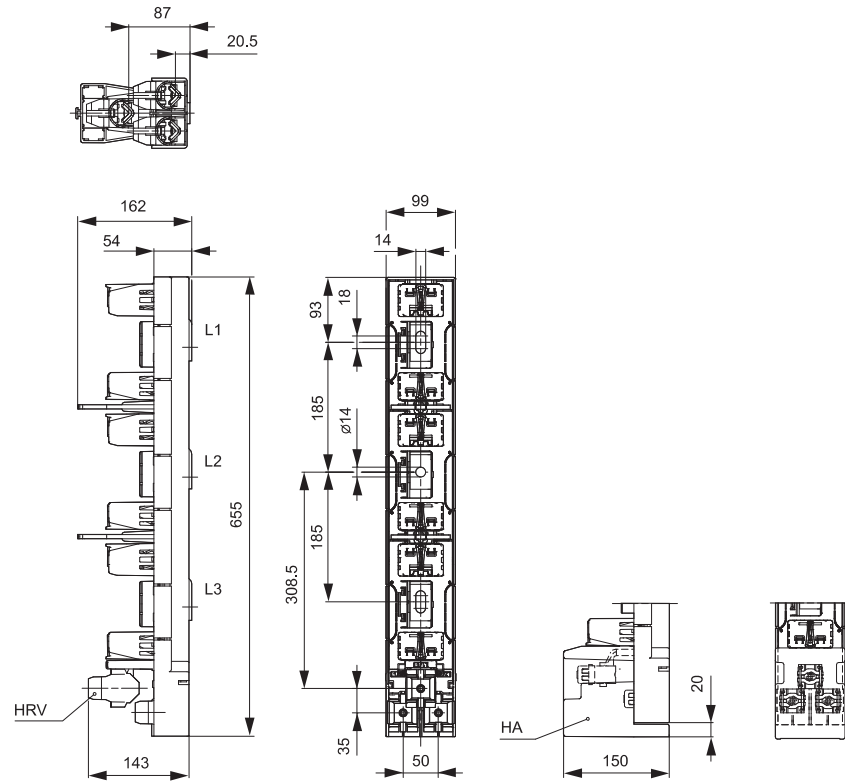

size 1, 2, 3 (SP terminal)

Dimensional overview of accessories for LV NV fuse-rails

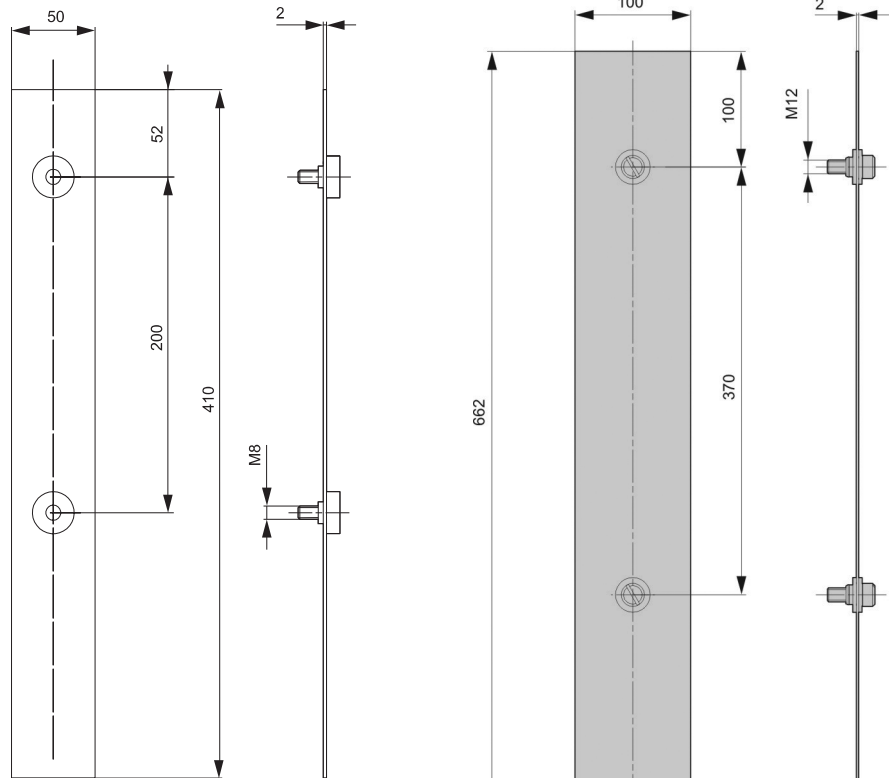

busbar covering PZ 00/100

busbar covering PZ 123/185, busbar covering PZ 00/185

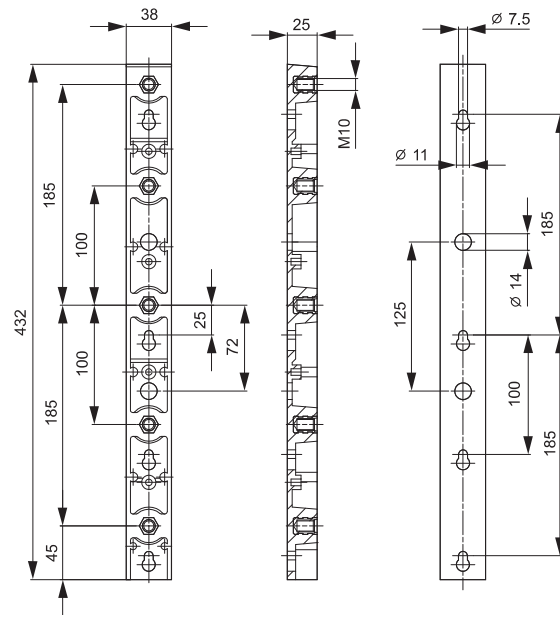
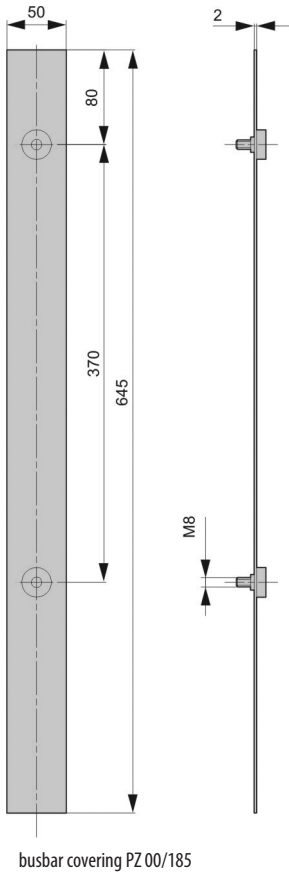

NV fuse-rail type VL00 EK

Technical data

Type	VL00/100 EK	
Conventional free air thermal current (Ith)	A	160
Rated insulation voltage	V	AC690
Rated withstand impulse voltage	Kv	6
Rated frequency	Hz	50 (40-60)
Power dissipation (without fuse-links)	W	16,6
Degree of protection (cover closed)		IP20
Degree of protection (cover opened)		IP20
Pollution degree		3
Permissible ambient temperature**	°C	-25°C ... +55°C
Storage temperature	°C	-30°C ... +70°C
Weight (without fuse-links)	kg	0,86
Package	pcs	1

** with ambient temperature between 40-45°C, reduce Ith by 5%;
with ambient temperature above 45°C, reduce Ith by 10%

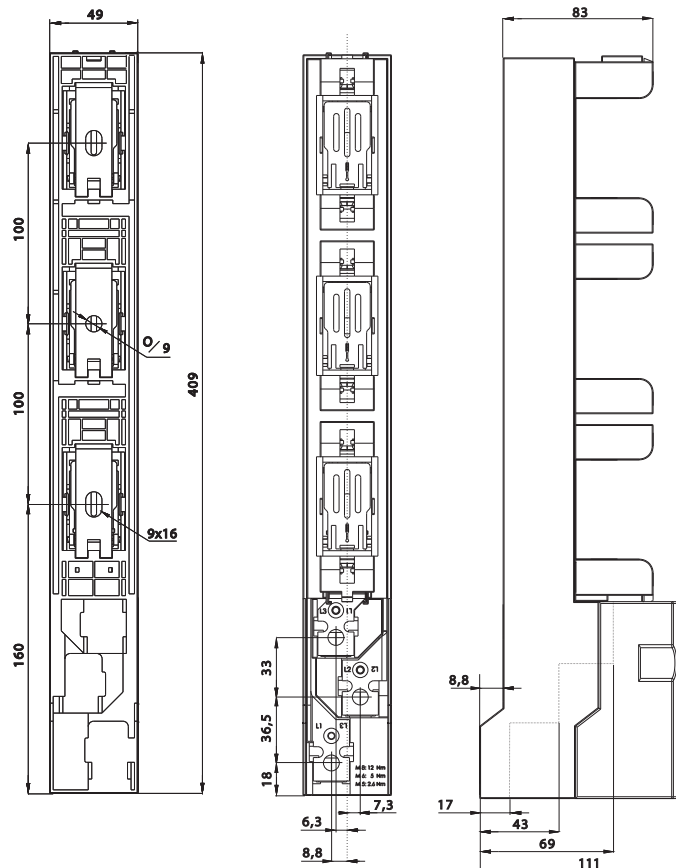

Technical data

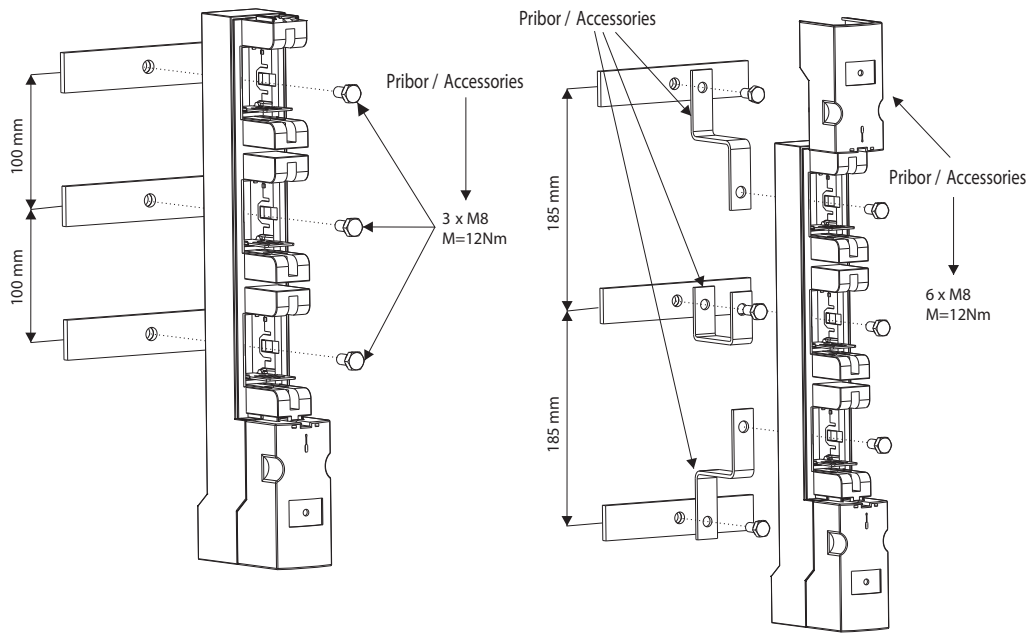

NV Strip type fuse-switch-disconnector sizes 00, 1, 2, 3

Technical data of NV strip type fuse-switch-disconnectors (in accordance with IEC/EN 60947-3)

Technical Specifications			SL00/100			SL00/185			SL1		
Electrical Characteristics											
Rated operational voltage	U_e	V	500 AC	690 AC	400 AC	500 AC	690 AC	400 AC	500 AC	690 AC	400 AC
Rated operational current	I_e	A	160	100	160	160	160	160	250	250	250
Rated frequency	-	Hz	40-60	40-60	40-60	40-60	40-60	40-60	40-60	40-60	40-60
Rated insulation voltage	U_i	V	AC 800						AC 1000		
Total power loss at I_n (without fuse)	P_v	W	18			23					
Utilization category	-	-	AC22B	AC22B	AC22B	AC23B	AC22B	AC23B	AC22B	AC22B	AC23B
Fuse links											
Size - DIN 43 620, IEC 60269-2	-	-	000/00						1		
Max. rated current (gG)	I_n	A	160	100	160	160	160	160	250	250	250
Max. permissible power loss per fuse link	P_v	W	12						32		
Dimensions											
Mass	-	kg	100 mm = 1,40			185mm=2,4			4,9		
Busbars (distance)	-	mm	100			185			185		
Cable connection											
Screw	-	-	M8						M10		
Torque	M_a	Nm	12-15						30-35		
V-clip	-	mm ²	10-95						25-300		
Torque	M_a	Nm	15						32		
Protection											
Operational state	-	-	IP30						IP30		
Cover open	-	-	IP10						IP10		
Operating conditions											
Ambient temperature	T_u	°C	-25 ... +55						-25 ... +55		
Operating condition	-	-	Continuous operation								
Mounting	-	-	vertical, horizontal								
Altitude	-	m	≤ 2000								
Pollution degree	-	-	3								
Overvoltage category	-	-	III			IV					

Technical data of NV strip type fuse-switch-disconnectors (in accordance with IEC/EN 60947-3)

Technical Specifications			SL1H			SL2		
Electrical Characteristics								
Rated operational voltage	U_e	V	500 AC	690 AC	400 AC	500 AC	690 AC	400 AC
Rated operational current	I_e	A	250			400	400	400
Rated frequency	-	Hz	40-60			40-60	40-60	40-60
Rated insulation voltage	U_i	V	AC 1000					
Total power loss at I_n (without fuse)	P_v	W	29			54		
Utilization category	-	-	AC22B	AC21B	AC23B	AC22B	AC21B	AC23B
Fuse links								
Size - DIN 43 620, IEC 60269-2	-	-	1			2		
Max. rated current (gG)	I_n	A	250			400	400	400
Max. permissible power loss per fuse link	P_v	W	23			45		
Dimensions								
Mass	-	kg	4,9					
Busbars (distance)	-	mm	185					
Cable connection								
Screw	-	-	M10			M12		
Torque	M_a	Nm	30-35			35-40		
V-clip	-	mm ²	25-240 / 25-300			25-300		
Torque	M_a	Nm	32					
Protection								
Operational state	-	-	IP30					
Front cover open	-	-	IP10					
Operating conditions								
Ambient temperature	T_u	°C	-25 ... +55					
Operating condition	-	-	Continuous operation					
Mounting	-	-	vertical, horizontal					
Altitude	-	m	≤ 2000					
Pollution degree	-	-	3					
Overvoltage category	-	-	IV					

Technical data of NV strip type fuse-switch-disconnectors (in accordance with IEC/EN 60947-3)

Technical Specifications			SL2H			SL3		
Electrical Characteristics								
Rated operational voltage	U_e	V	500 AC	690 AC	400 AC	500 AC	690 AC	400 AC
Rated operational current	I_e	A	400			630	630	630
Rated frequency	-	Hz	40-60			40-60	40-60	40-60
Rated insulation voltage	U_i	V	AC 1000					
Total power loss at I_n (without fuse)	P_v	W	73			115		
Utilization category	-	-	AC22B	AC21B	AC23B	AC22B	AC21B	AC23B
Fuse links								
Size - DIN 43 620, IEC 60269-2	-	-	2			3		
Max. rated current (gG)	I_n	A	400			630	630	630
Max. permissible power loss per fuse link	P_v	W	34			48		
Dimensions								
Mass	-	kg	4,9			5,6		
Busbars (distance)	-	mm	185					
Cable connection								
Screw	-	-	M12			M12		
Torque	M_a	Nm	35-40			35-40		
V-clip	-	mm ²	25-240 / 25-300			25-300		
Torque	M_a	Nm	32					
Protection								
Operational state	-	-	IP30					
Front cover open	-	-	IP10					
Operating conditions								
Ambient temperature	T_u	°C	-25 ... +55					
Operating condition	-	-	Continuous operation					
Mounting	-	-	vertical, horizontal					
Altitude	-	m	≤ 2000					
Pollution degree	-	-	3					
Overvoltage category	-	-	IV					

Dimensional overview of NV strip type fuse-switch-disconnectors

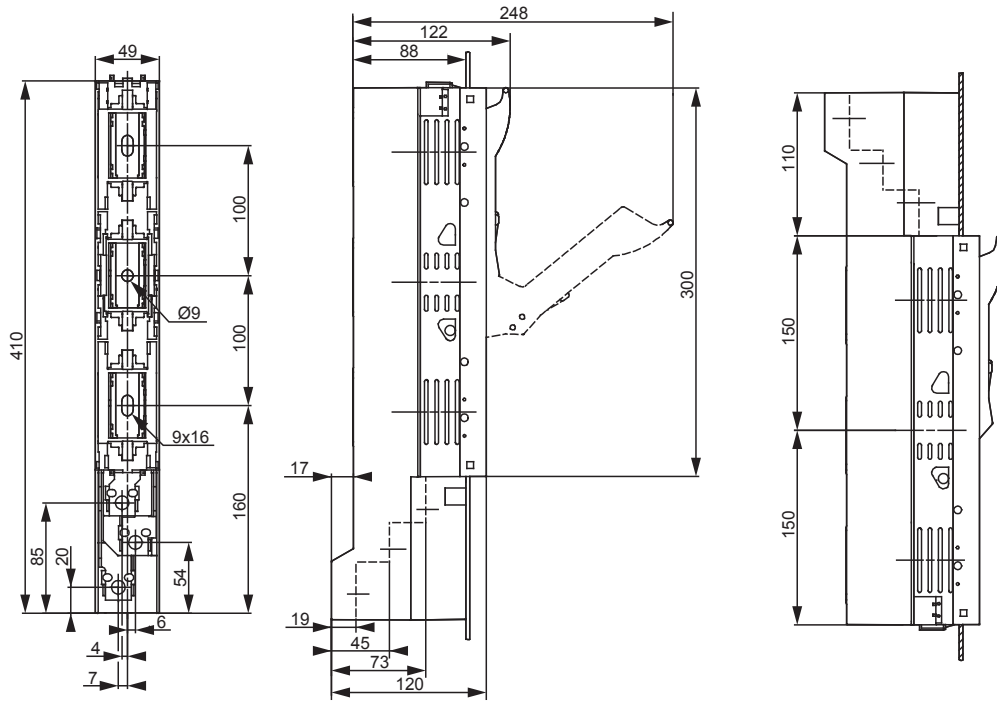

SL00/100

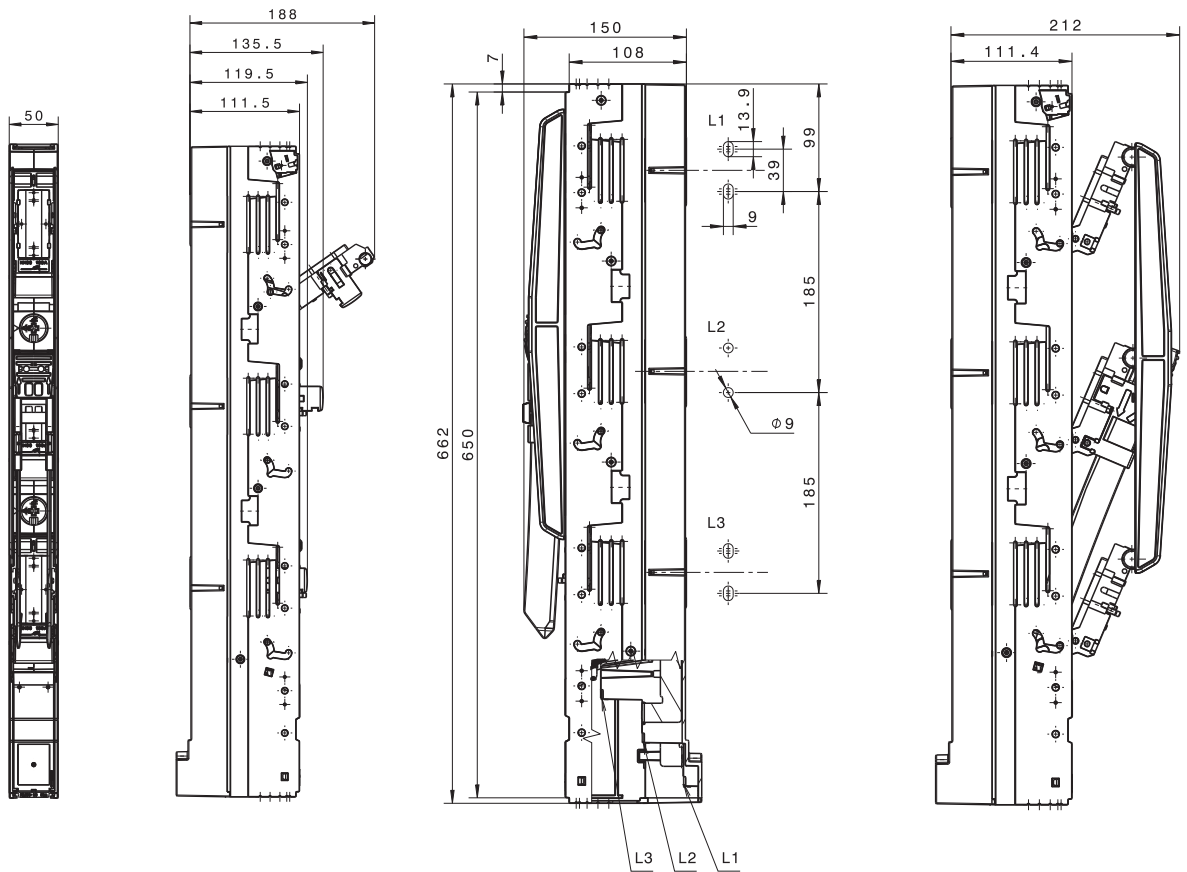

SL00/185

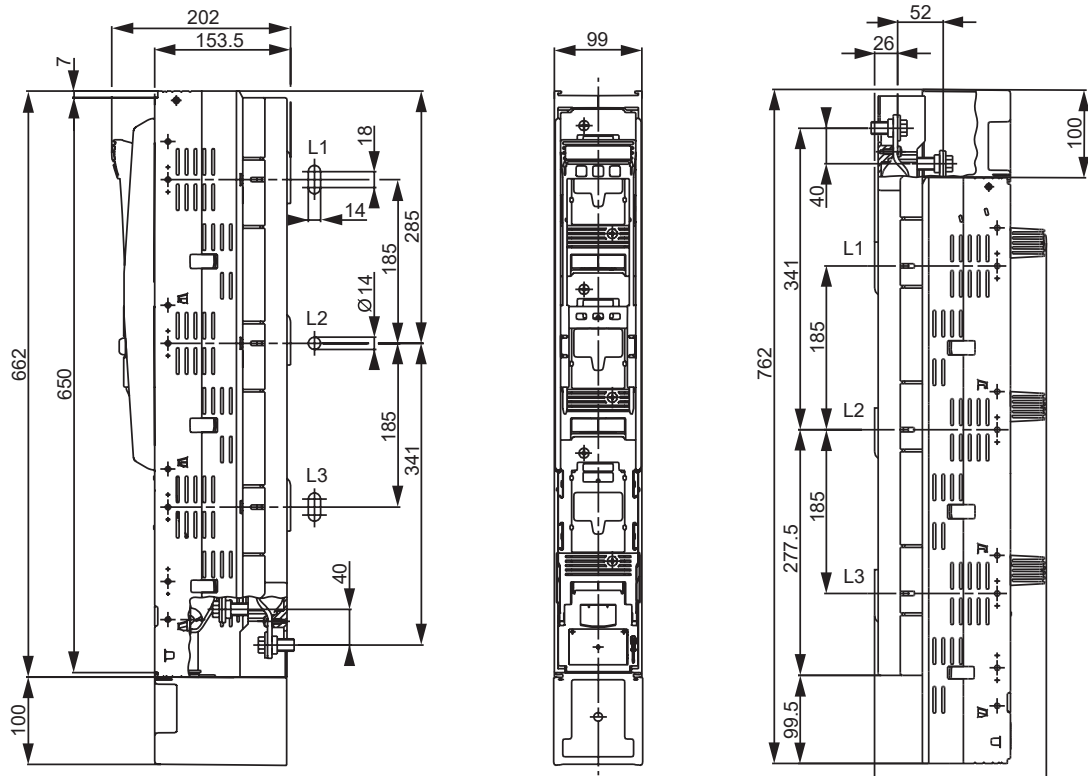

SL1(H), SL2(H), SL3

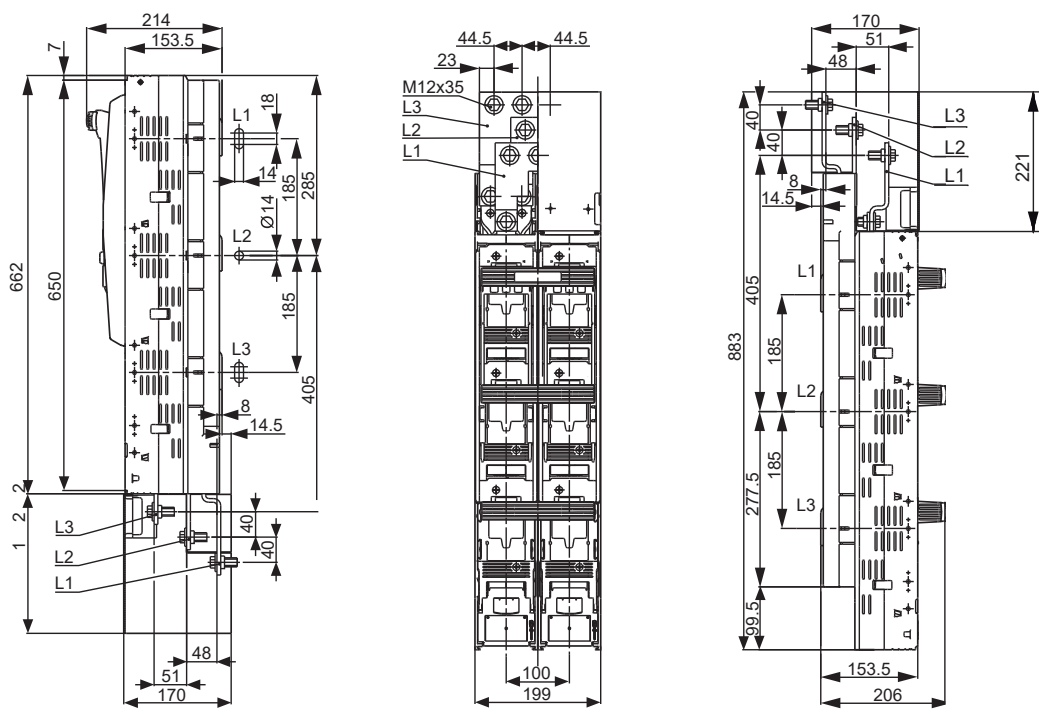

SL3 DOUBLE

NV/NH

Technical data

Dimensional overview of accessories for NV strip type fuse-switch-disconnectors

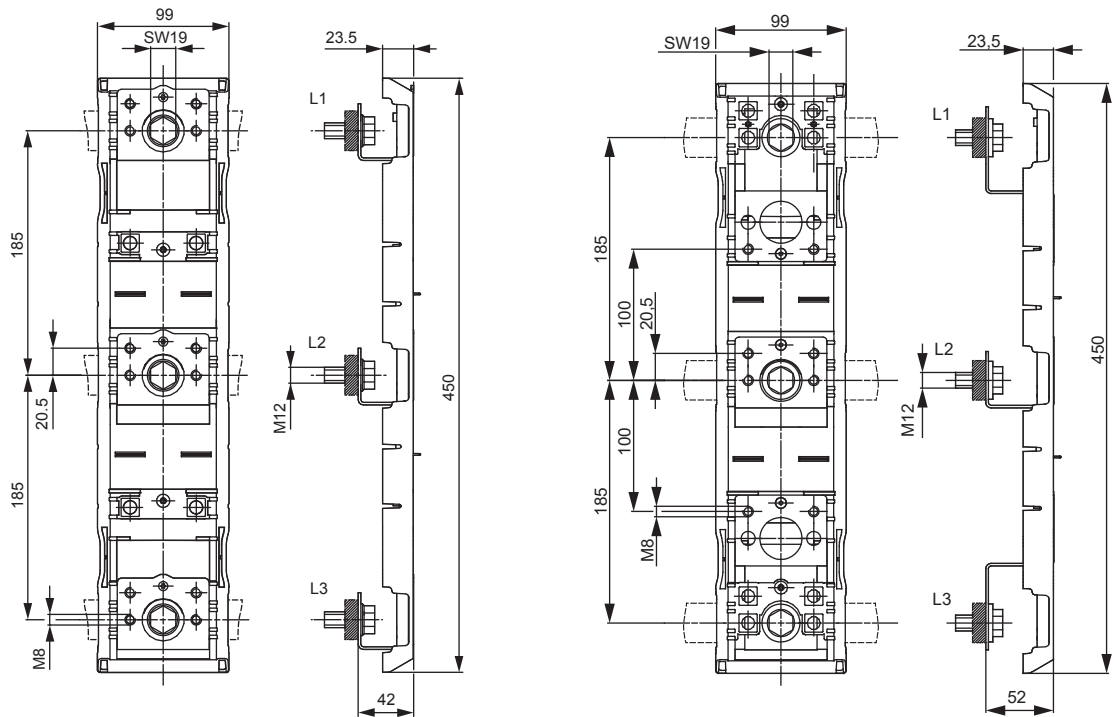

adapter DA 185-185/42

adapter DA 185-100/52

Strip type fuse-switch disconnectors type SL00 EK

Technical data		SL00/100 EK		
Type				
Conventional free air thermal current (I _{th})	A	160		
Rated insulation voltage	V	AC690		
Rated withstand impulse voltage	Kv	6		
Rated frequency	Hz	50 (40-60)		
Rated operational (making and breaking) voltage	V	400V	500V	690 V
Utilization category/Rated operational (making and breaking) current	AC21-B	160A	160A	125A
Utilization category/Rated operational (making and breaking) current	AC22-B	160A	160A	100A
Rated conditional short-circuit current	kA _{eff}	63		
Mechanical durability (operating cycles)		1400		
Electrical durability (operating cycles)		200		
Power dissipation (without fuse-links)	W	19,5		
Degree of protection (cover closed)		IP30		
Degree of protection (cover opened)		IP20		
Pollution degree		3		
Permissible ambient temperature**	°C	-25°C ... +55°C		
Storage temperature	°C	-30°C ... +70°C		
Weight (without fuse-links)	kg	1,2		
Package	pcs	1		

** with ambient temperature between 40-45°C, reduce I_{th} by 5%; with ambient temperature above 45°C, reduce I_{th} by 10%

Dimensions

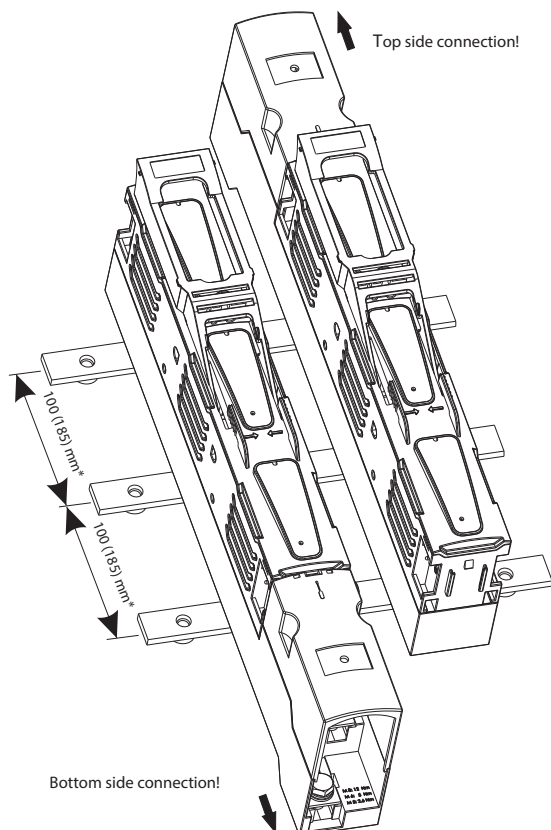
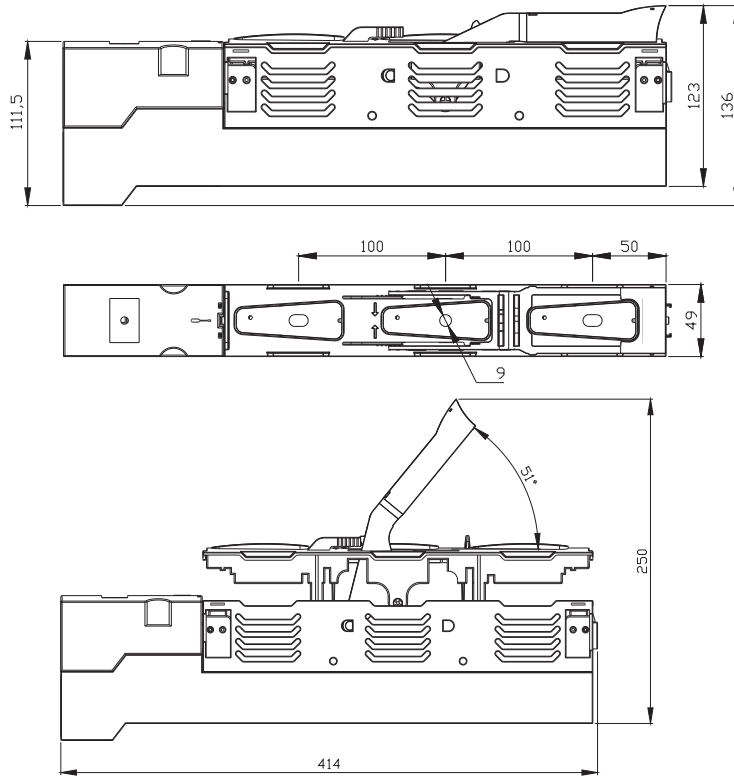

Technical data

Horizontal fuse-switch disconnecter type KVL size 00, 1, 2, 3 (baseplate mounting)

Technical data (in accordance with IEC/EN 60947-3)

Size	00						1							
Technical Characteristics														
Rated operational voltage	U _e	V	400 AC	500 AC	690 AC	250 DC	440 DC	400 AC	500 AC	690 AC	250 DC	440 DC		
Rated operational current*	I _e	A	160	160	160	160	160	250	250	250	250	250		
Conv. free air thermal current with fuse-links*	I _{th}	A	160						250					
Conv. free air thermal current with solid-links*	I _{th}	A	210						325					
Rated frequency	f	Hz	40-60	40-60	40-60	/	/	40-60	40-60	40-60	/	/		
Rated insulation voltage	U _i	V	800 AC						800 AC					
Total power loss (without fuse)	P _v	W	1P - 3W, 3P - 9W						1P - 5W, 3P - 15W					
Power loss at 80% I _{th} (without fuse-links), **	P _v	W	1P - 1,9W, 3P - 5,8W						1P - 3,2W, 3P - 9,6W					
Rated impulse withstand voltage	U _{imp}	kV	8						8					
Utilisation category***			AC-23B	AC-22B	AC-21B	DC-22B	DC-21B	AC-23B	AC-22B	AC-21B	DC-22B	DC-21B		
Rated conditional short-circuit current, ***, ****		kA	120 (500V), 100 (690V)						120 (500V), 100 (690V)					
Rated short-time withstand current	I _{cw}	kA	5/1s						8,6/1s					
Fuse links														
Size - DIN VDE 0636-2	-	-	000/00						1					
Max. rated current (gG)	I _n	A	160	160	160	160	160	250	250	250	250	250		
Max. permissible power loss per fuse link	P _a	W	12						23					
Cable terminal														
Flat terminal-Screw			M8						M10					
Tightening torque	Ma	Nm	12-15						30-35					
Clip terminal, Clamping cross-section		mm ²	Round conductor: 1,5-70 Cu, Strip conductor: 6 x 9 x 0,8 Cu						Round conductor: 2,5-150 Cu, Strip conductor: 6 x 16 x 0,8 Cu					
Tightening torque	Ma	Nm	2,6						9,5					
Prism Clamp, Clamping cross-section		mm ²	(SP KVL00 P1); 10-70 Al/Cu, 35-95 Al/Cu						(SP KVL1 P1); 10-150 Al/Cu					
Tightening torque	Ma	Nm	(SP KVL00 P1); 2,6						(SP KVL1 P1); 4,5					
Prism Clamp, Clamping cross-section		mm ²							(SP KVL1 P2); 2 x (10-150) Al/Cu					
Tightening torque	Ma	Nm							(SP KVL1 P2); 4,5					
Frame clamp, Clamping cross-section		mm ²	1,5-95 Al/Cu, (Al 95: max. 125A), *****						35-150 Al/Cu					
Torque	Ma	Nm	4,5						12					
Degree of Protection, front side device														
Front cover close	-	-	IP20						IP20					
Front cover open	-	-	IP10						IP10					
With clamp- and lateral cover	-	-	IP2XC						IP2XC					
Operating condition														
Ambient temperature *****	T _{amb}	°C	-25 ... +55						-25 ... +55					
Operating condition	-	-							Continuous operation					
Mounting	-	-							vertical, horizontal					
Altitude	-	m							≤ 2000					
Pollution degree	-	-							3					
Overvoltage category	-	-	III						III					

* Mounting of several units in low voltage switchgear-combinations, please think about rated diversity factors acc. to DIN EN 61439.

** Reference value for replacement of devices acc. to DIN EN 61439-1 clause 10.10.4.2.

*** minimum distance to earthed, conductive parts: Lateral: 20mm/Above: 50mm

*** a) Lateral: 50mm/Above: 100mm

**** Type tested with NH fuse-links characteristic gG

***** 35°C Normal temperature, at 55°C with reduced operating current

Technical data (in accordance with IEC/EN 60947-3)										
Size	2					3				
Technical Characteristics										
Rated operational voltage	U_e	V	400 AC	500 AC	690 AC	440 DC	400 AC	500 AC	690 AC	440 DC
Rated operational current*	I_e	A	400	400	400	400	630	630	630	630
Conv. free air thermal current with fuse-links*	I_{th}	A	400				630			
Conv. free air thermal current with solid-links*	I_{th}	A	520				910			
Rated frequency	f	Hz	40-60	40-60	40-60	/	40-60	40-60	40-60	/
Rated insulation voltage	U_i	V	800 AC				800 AC			
Total power loss (without fuse)	P_v	W	1P - 9W, 3P - 28W				1P - 17W, 3P - 51W			
Power loss at 80% I _{th} (without fuse-links), **	P_v	W	1P - 6 W, 3P - 17,9 W				1P - 10,9 W, 3P - 32,6 W			
Rated impulse withstand voltage	U_{mp}	kV	8				8			
Utilisation category***			AC-23B	AC-22B	AC-21B	DC-22B	AC-23B	AC-22B	AC-21B	DC-22B
Rated conditional short-circuit current, ***, ****		kA	120 (500V), 100 (690V)				120 (500V), 100 (690V)			
Rated short-time withstand current	I_{cw}	kA	15/1s				15/1s			
Fuse links										
Size - DIN VDE 0636-2	-	-	2				3			
Max. rated current (gG)	I_n	A	400	400	400	400	630	630	630	630
Max. permissible power loss per fuse link	P_a	W	34				48			
Cable terminal										
Flat terminal-Screw			M10				M10 / M12			
Tightening torque	M_a	Nm	30-35				30-35			
Clip terminal, Clamping cross-section		mm ²	Round conductor: 25-150 Cu, Strip conductor: 10 x 16 x 0,8 Cu				Strip conductor: 11 x 21 x 1 Cu			
Tightening torque	M_a	Nm	23				23			
Prism Clamp, Clamping cross-section		mm ²	(SP KVL2 P1); 120-240 Al/Cu				(SP KVL3 P1); 120-300 Al/Cu			
Tightening torque	M_a	Nm	(SP KVL2 P1); 11				(SP KVL3 P1); 11			
Prism Clamp, Clamping cross-section		mm ²	(SP KVL2 P2); 2 x (120-150) Al/Cu				(SP KVL3 P2); 2 x (120-240) Al/Cu			
Tightening torque	M_a	Nm	(SP KVL2 P2); 11				(SP KVL3 P2); 11			
Frame clamp, Clamping cross-section		mm ²	95-300 Al/Cu				95-300 Al/Cu			
Torque	M_a	Nm	20				20			
Degree of Protection, front side device										
Front cover close	-	-	IP20				IP20			
Front cover open	-	-	IP10				IP10			
With clamp- and lateral cover	-	-	IP2XC				IP2XC			
Operating condition										
Ambient temperature *****	T_{amb}	°C	-25 ... +55				-25 ... +55			
Operating condition	-	-	Continuous operation							
Mounting	-	-	vertical, horizontal							
Altitude	-	m	≤ 2000							
Pollution degree	-	-	3							
Overvoltage category	-	-	III				III			

* Mounting of several units in low voltage switchgear-combinations, please think about rated diversity factors acc. to DIN EN 61439.

** Reference value for replacement of devices acc. to DIN EN 61439-1 clause 10.10.4.2.

*** minimum distance to earthed, conductive parts: Lateral: 20mm/Above: 50mm

*** a) Lateral: 50mm/Above: 100mm

**** Type tested with NH fuse-links characteristic gG

***** 35°C Normal temperature, at 55°C with reduced operating current

Technical data

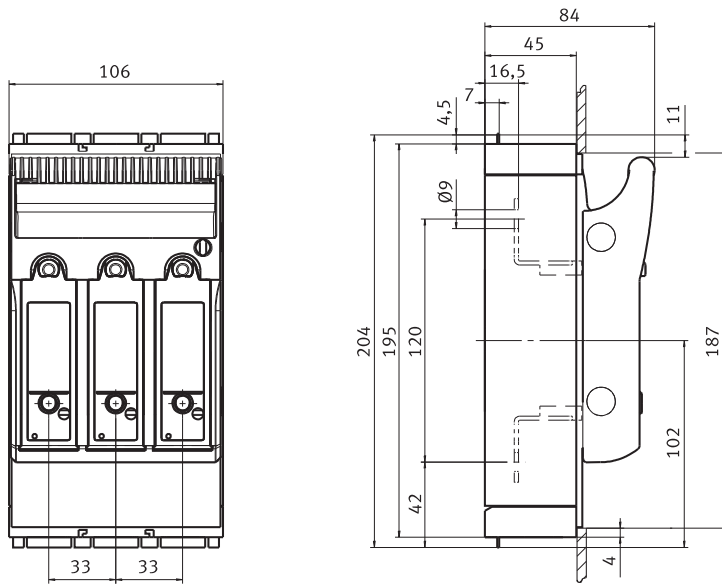

KVL-00 3p M8-M8
KVL-00 3p BC95-BC95
KVL-00 3p M8-M8 LED
KVL-00 3p BC95-BC95 LED

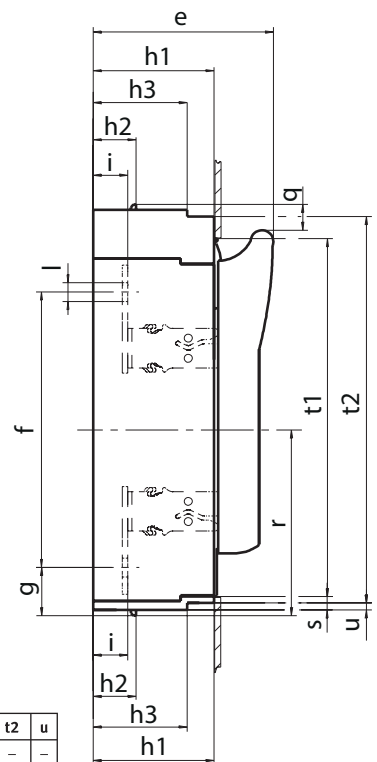
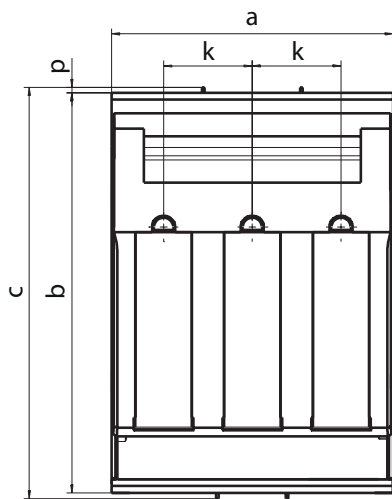

	a	b	c	e	f	g	h1	h2	h3	i	k	l	p	q	r	s	t1	t2	u
KVL-1 3p M10-M10 (LED)	184	298	306	117	185	46	70	32	-	25	58	Ø10,5	4	19	138	5	272	-	-
KVL-2 3p M10-M10 (LED)	210	298	306	134	205	36	90	32	70	26	66	Ø14	4	19	138	10	268	288	5
KVL-3 3p M10-M10 (LED)	250	298	306	143	205	36	90	32	70	26	82	Ø14	4	19	138	10	268	288	5

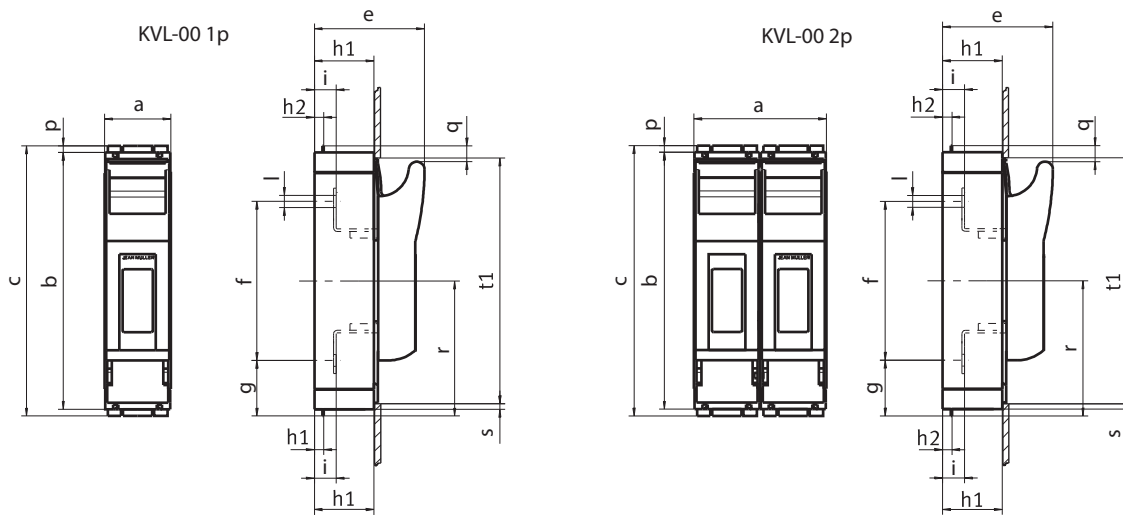

	a	b	c	e	f	g	h1	h2	h3	i	l	p	q	r	s	t1
KVL-00 1p M8-M8	50	195	204	84	120	42	45	7	-	16,5	∅9	4,5	12	102	5	187
KVL-00 2p M8-M8	100	195	204	84	120	42	45	7	-	16,5	∅9	4,5	12	102	5	187

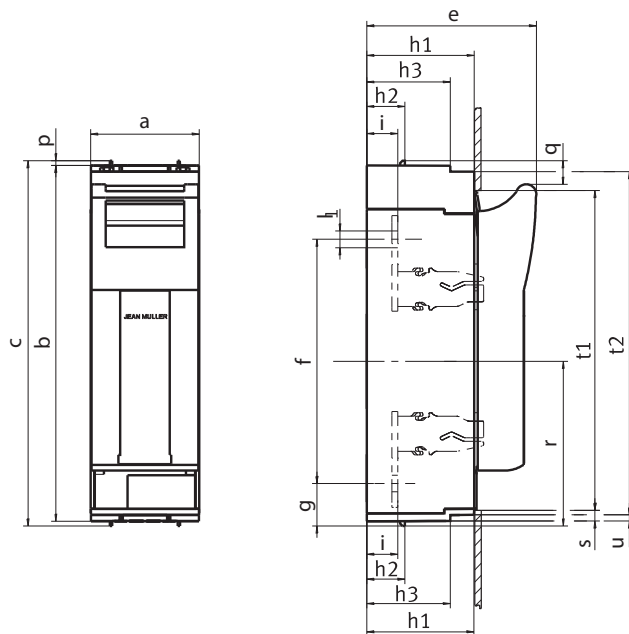

	a	b	c	e	f	g	h1	h2	h3	i	l	p	q	r	s	t1	t2	u
KVL-1 1p M10-M10	69	298	306	117	185	46	70	32	-	25	∅10,5	4	19	138	5	272	-	-
KVL-3 1p M10-M10	91	298	306	143	205	36	90	32	70	26	∅14	4	19	138	10	268	288	5

Technical data

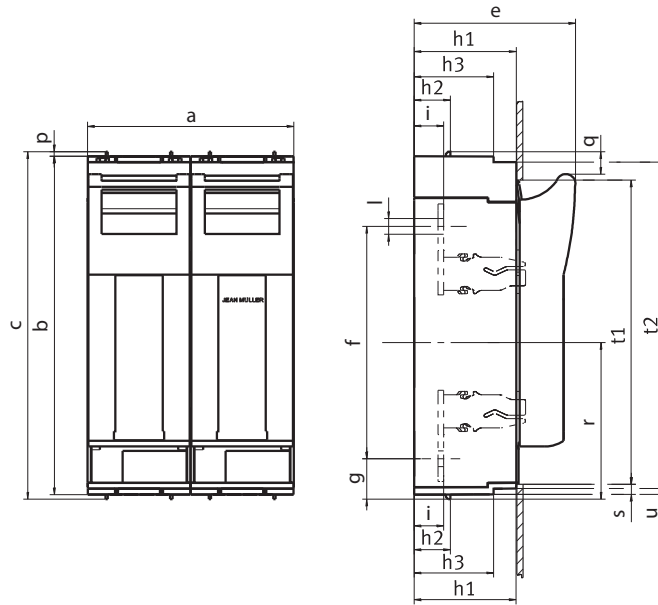

	a	b	c	e	f	g	h1	h2	h3	i	l	p	q	r	s	t1	t2	u
KVL-1 2p M10-M10	138	298	306	117	185	46	70	32	-	25	Ø10,5	4	19	138	5	272	-	-
KVL-3 2p M10-M10	182	298	306	143	205	36	90	32	70	26	Ø14	4	19	138	10	268	288	5

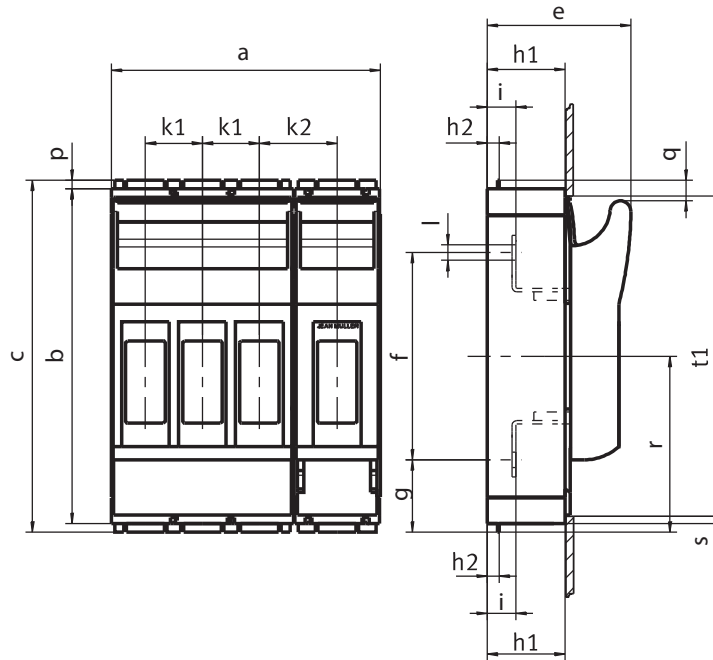

	a	b	c	e	f	g	h1	h2	h3	k1	k2	i	l	p	q	r	s	t1	t2	u
KVL-00 4p M8-M8	156	195	204	84	120	42	45	7	-	33	45	16,5	Ø9	4,5	12	102	5	187	-	-

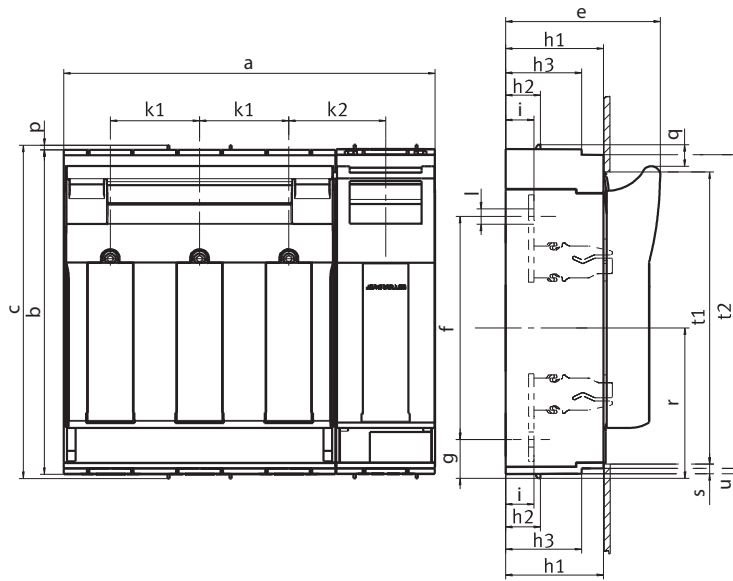

	a	b	c	e	f	g	h1	h2	h3	k1	k2	i	l	p	q	r	s	t1	t2	u
KVL-1 4p	254	298	306	117	185	46	70	32	-	58	69	25	Ø10,5	4	19	138	5	272	-	-
KVL-3 4p	341,5	298	306	143	205	36	90	32	70	82	89	26	Ø14	4	19	138	10	268	288	5

Technical data - Feeding clamps

Technical Characteristics

Max. electrical load			AC690V/DC1000V-250A
Heat deflection temp.			125°C UL94: V0
Comparative tracking index			600

Cross sections

Conductor - Max. Diameter Ø14 mm			
single wire		mm ²	25 - 95
multi wire		mm ²	25 - 95
fine wire (with end sleeve)		mm ²	25 - 70
Torque	Ma	Nm	13
Degree of protection			IP20
Regulations			EN 60998-1:2004; EN 60998-2:2004; EN 60999-1:2000; EN 60999-2:2003

Important

This Terminal is suitable for Al and Cu conductors. Please pay attention to the common handling guidelines when connecting the Aluminium conductors. Clean and brush the contact surfaces and lubricate them with an appropriate grease.

Technical data

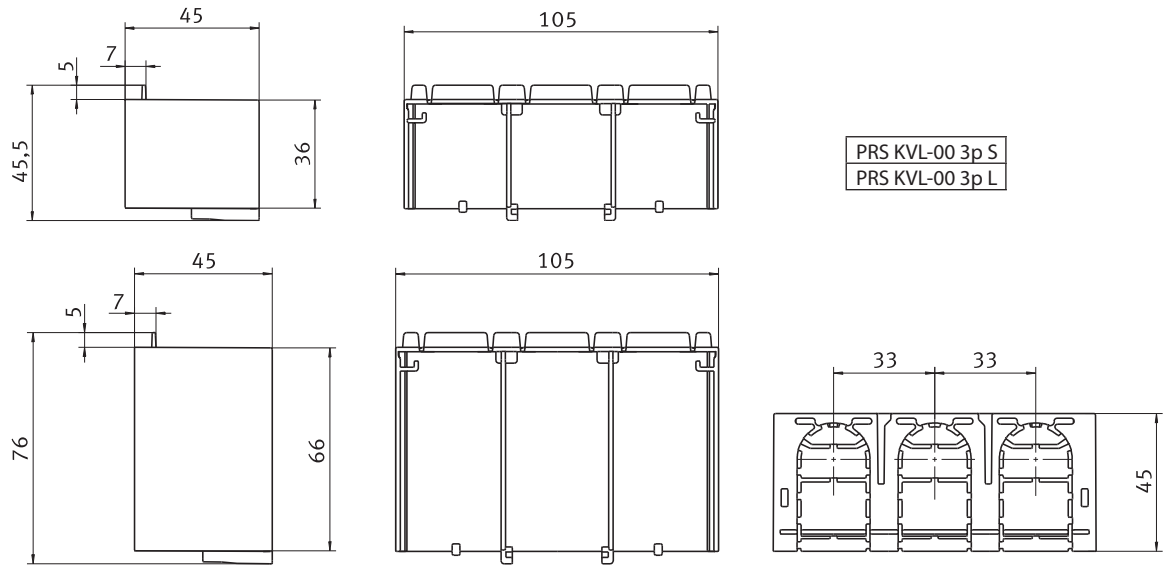

PRS KVL-00 3p S
PRS KVL-00 3p L

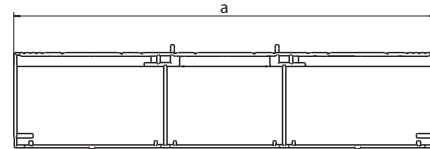
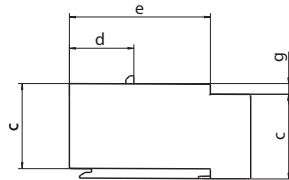

	a	b	c	d	e	f	g
PRS KVL-1 3p	184	70	42	32	-	58	-
PRS KVL-2 3p	210	90	42	32	70	66	5
PRS KVL-3 3p	250	90	42	32	70	82	5

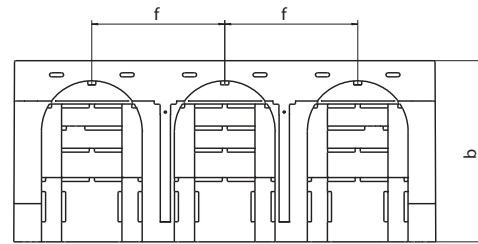

PRS KVL-00 1p L

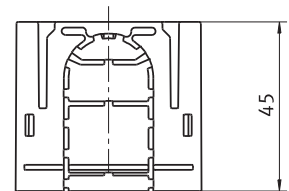
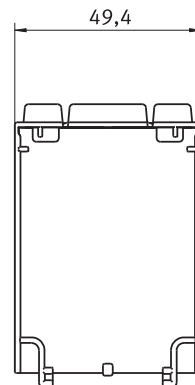
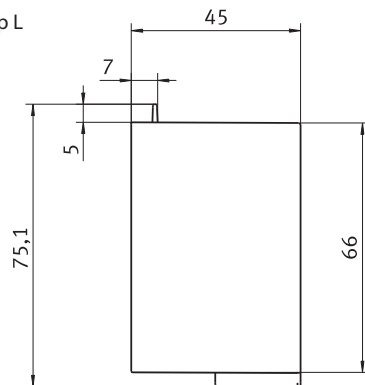

PRS KVL-00 1p S

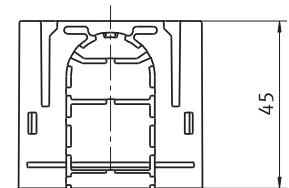
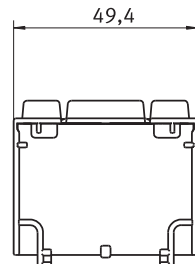
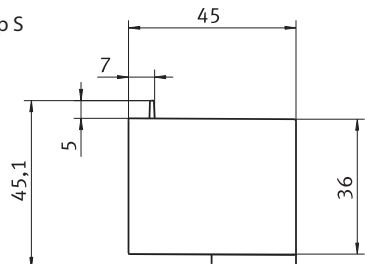

PRS KVL-1 1p

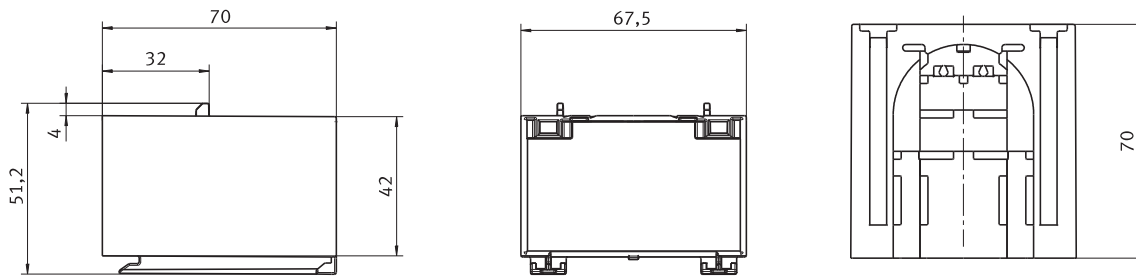

PRS KVL-3 1p

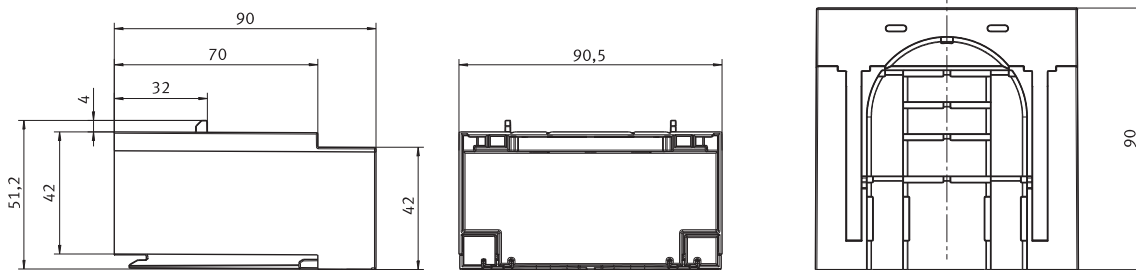

Technical data - Electronic fuse monitoring unit EFMU KVL			
Technical Characteristics			
Rated operational voltage	U_e	V	AC400-500 (+/-10%)
Power supply			Self-powered
Input power		VA	1,5
Overvoltage category			230/400 V : III , (4kV) 500 V : II , (4kV)
Rated frequency	f	Hz	50-60
Input resistance			>1k Ohm/V
Output channels			
Relay output			1NC/1NO
Maximum voltage		V	AC250/DC24
Maximum switching current		A	1
General data			
Operation indicator			1 LED green
Alarm indicator			3 LED (F1, F2, F3) red
Functional test			Test key for relay + LEDs
EMC			IEC 61000-4-5/IEC 61000-4-4
Degree of protection			IP 3X
Operating conditions			
Ambient temperature	T_{amb}	°C	-5 ... +55

No single detection of parallel connected fuses!

Technical data

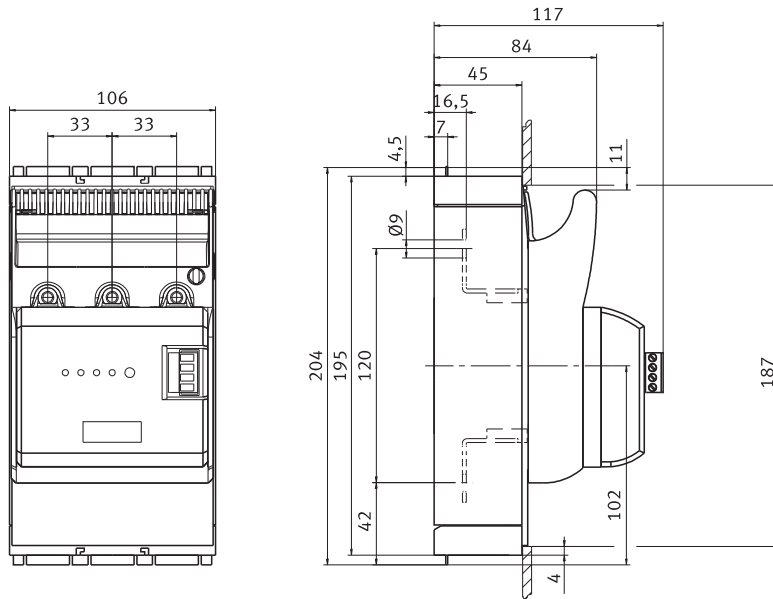

KVL-00 3p M8-M8 + EFMU KVL-00 3p
 KVL-00 3p BC95-BC95 + EFMU KVL-00 3p

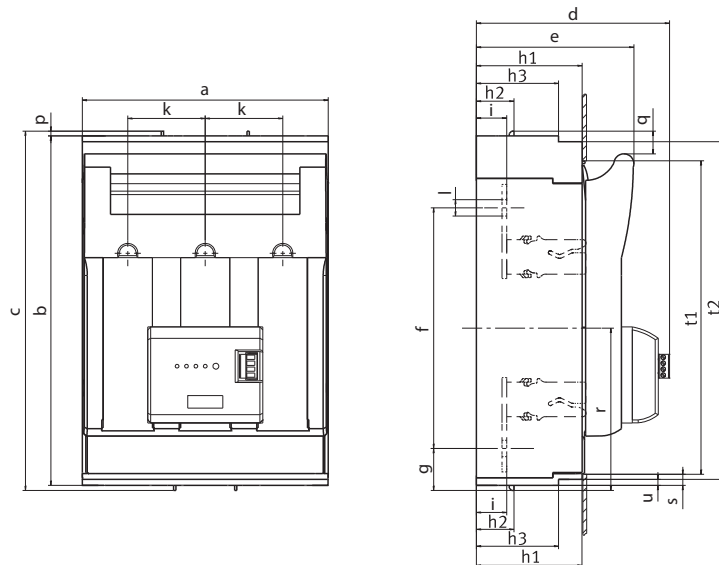

	a	b	c	d	e	f	g	h1	h2	h3	i	k	l	p	q	r	s	t1	t2	u
KVL-1 3p M10-M10 + EFMU KVL-1 3p	184	298	306	148	117	185	46	70	32	-	25	58	Ø10,5	4	19	138	5	272	-	-
KVL-2 3p M10-M10 + EFMU KVL-2 3p	210	298	306	165	134	205	36	90	32	70	26	66	Ø14	4	19	138	10	268	288	5
KVL-3 3p M10-M10 + EFMU KVL-3 3p	250	298	306	173	143	205	36	90	32	70	26	82	Ø14	4	19	138	10	268	288	5

Technical data - Electromechanical fuse monitoring unit MPFMU KVL

Technical Characteristics

Rated operational voltage	U_e	V	"AC24...690 DC24...150"
Rated short-circuit breaking capacity	I_{cn}	kA	100
Overvoltage category			230/400V : III (4kV) 500V : II (4kV)
Output channels			
Relay output			1NC/1NO
Maximum voltage		V	AC230/DC24
Maximum switching current		A	AC3/DC1

No single detection of parallel connected fuses!

Safety notes

May not be used for safety monitoring in feeders with power control units where, in the event of a fault, it is possible for a DC feedback of >300V (or >600V where 3 current paths are connected in parallel) to occur. If equipment has to be disconnected on the load side of the fuses to be monitored, make sure that no parasitic voltages can arise in the circuit-breaker that is connected in parallel with the fuse-monitoring device.

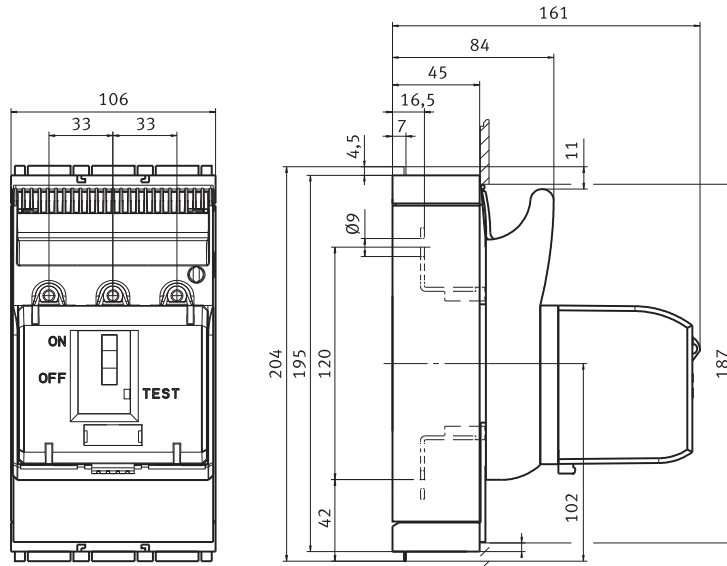

KVL-00 3p M8-M8 + MPFMU KVL-00 3p
KVL-00 3p BC95-BC95 + MPFMU KVL-00 3p

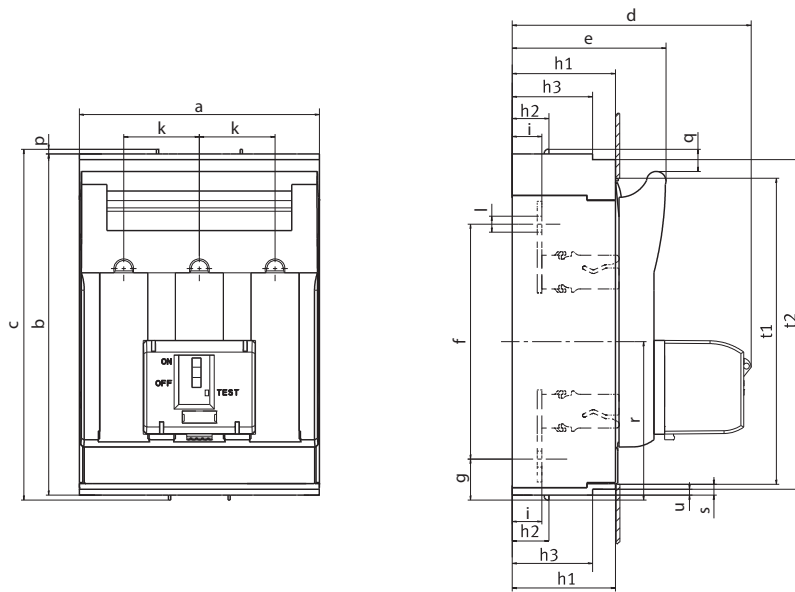

	a	b	c	d	e	f	g	h1	h2	h3	i	k	l	p	q	r	s	t1	t2	u
KVL-1 3p M10-M10 + MPFMU KVL-1 3p	184	298	306	192	117	185	46	70	32	-	25	58	Ø10,5	4	19	138	5	272	-	-
KVL-2 3p M10-M10 + MPFMU KVL-2 3p	210	298	306	209	134	205	36	90	32	70	26	66	Ø14	4	19	138	10	268	288	5
KVL-3 3p M10-M10 + MPFMU KVL-3 3p	250	298	306	217	143	205	36	90	32	70	26	82	Ø14	4	19	138	10	268	288	5

Horizontal fuse-switch disconnecter type HVL size 00, 1, 2, 3 and 4a

Technical data (in accordance with IEC/EN 60947-3)										
Technical Specifications			Size 00				Size 1			
Technical Characteristics										
Rated operational voltage	U_e	V	500 AC	690 AC	220 DC	440 DC	500 AC	690 AC	220 DC	440 DC
Rated operational current	I_e	A	160	100	160	100	250	200	250	200
Rated frequency	-	Hz	40-60	40-60	-	-	40-60	40-60	-	-
Rated insulation voltage	U_i	V	800 AC				800 AC			
Total power loss (without fuse)	P_v	W	7				13			
Utilisation category	-	-	AC22B	AC22B	DC22B	DC21B	AC22B	AC22B	DC22B	DC21B
Fuse links										
Size - DIN 43 620, IEC 6269-2	-	-	000/00				1			
Max. rated current (gG)	I_n	A	160	100	160	100	250	200	250	200
Max. permissible power loss per fuse link	P_v	W	12				23			
Screw	-	-	M8				M10			
Torque	M_a	Nm	12-15				30-35			
Clamp	-	mm ²	1,5-70				25-150			
Torque	M_a	Nm	2,6				9,5			
Protection										
Front cover close	-	-	IP20				IP20			
Front cover open	-	-	IP10				IP10			
Operating condition										
Ambient temperature	T_u	°C	-25 ... +55				-25 ... +55			
Operating condition	-	-	Continuous operation							
Mounting	-	-	vertical, horizontal							
Altitude	-	m	≤ 2000							
Pollution degree	-	-	3							
Overvoltage category	-	-	III				III			

Technical data (in accordance with IEC/EN 60947-3)										
Technical Specifications			Size 2				Size 3			
Technical Characteristics										
Rated operational voltage	U_e	V	500 AC	690 AC	220 DC	440 DC	500 AC	690 AC	220 DC	440 DC
Rated operational current	I_e	A	400	315	400	315	630	500	630	500
Rated frequency	-	Hz	40-60	40-60	-	-	40-60	40-60	-	-
Rated insulation voltage	U_i	V	800 AC				800 AC			
Total power loss (without fuse)	P_v	W	27				52			
Utilisation category	-	-	AC22B	AC22B	DC22B	DC21B	AC22B	AC22B	DC22B	DC21B
Fuse links										
Size - DIN 43 620, IEC 6269-2	-	-	2				3			
Max. rated current (gG/gL)	I_n	A	400	315	400	315	630	500	630	500
Max. permissible power loss per fuse link	P_v	W	34				48			
Screw	-	-	M10				M10			
Torque	M_a	Nm	30-35				30-35			
Clamp	-	mm ²	25-240				25-240			
Torque	M_a	Nm	23				23			
Protection										
Front cover close	-	-	IP20				IP20			
Front cover open	-	-	IP10				IP10			
Operating condition										
Ambient temperature	T_u	°C	-25 ... +55				-25 ... +55			
Operating condition	-	-	Continuous operation							
Mounting	-	-	vertical, horizontal							
Altitude	-	m	≤ 2000							
Pollution degree	-	-	3							
Overvoltage category	-	-	III				III			

Technical data (in accordance with IEC/EN 60947-3)

Technical Specifications			Size 4a/1250	Size 4a/1600
Technical Characteristics				
Rated operational voltage	U_e	V	690 AC	690 AC
Rated operational current	I_e	A	1250	1600
Rated frequency	-	Hz	40-60	40-60
Rated insulation voltage	U_i	V	AC800	AC800
Total power loss (without fuse)	P_v	W	32	52
Utilisation category	-	-	AC22B (500V/1250A) AC21B (690V/1000A)	AC22B (500V/1600A) AC21B (690V/1000A)
Fuse links				
Size - DIN 43 620, IEC 6269-2	-	-	4a	4a
Max. permissible power loss per fuse link	P_v	W	110	164
Screw	-	-	1xM16	2xM12
Torque	M_a	Nm	50-60	35-40
Protection				
Front cover close	-	-	IP20	IP20
Front cover open	-	-	IP10	IP10
Operating condition				
Ambient temperature	T_u	°C	-25 ... +55	-25 ... +55
Operating condition	-	-	Continuous operation	
Mounting	-	-	vertical, horizontal	
Altitude	-	m	≤ 2000	
Pollution degree	-	-	3	
Overvoltage category	-	-	III	III

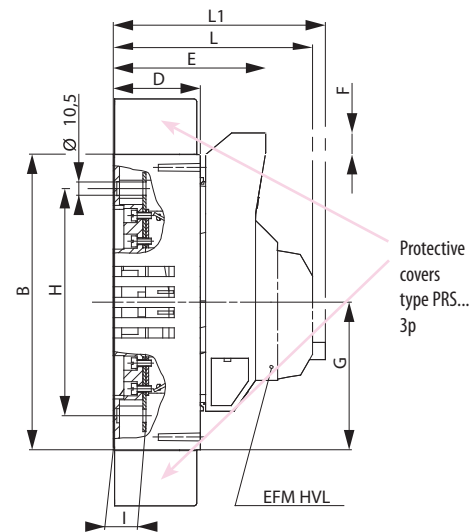
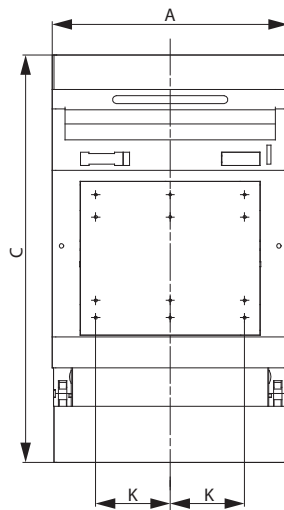
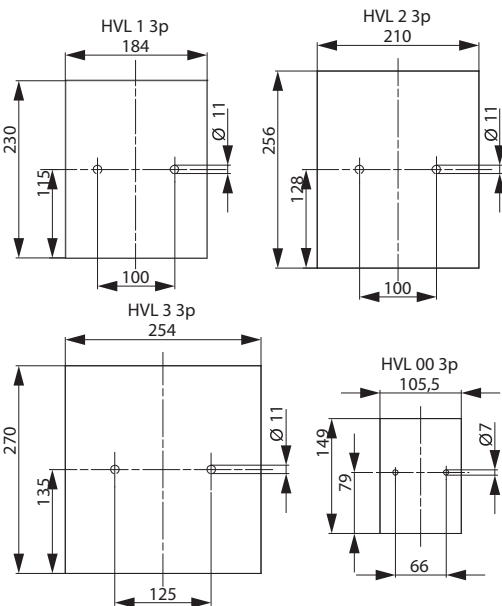

	A	B	C	D	E	F	G	H	I	K	L	L1
HVL00 3p	105,5	149	220	45	86	20,5	74,5	120	17	33	116	126
HVL1 3p	184	230	317	68	119	16,5	115	177	25	58	149	159
HVL2 3p	210	256	397	81	133	16,5	128	205	25	66	163	173
HVL3 3p	254	270	430	96	147	9	135	220,5	30,5	82	177	187

HVL 00,1,2,3 - 3p

Technical data

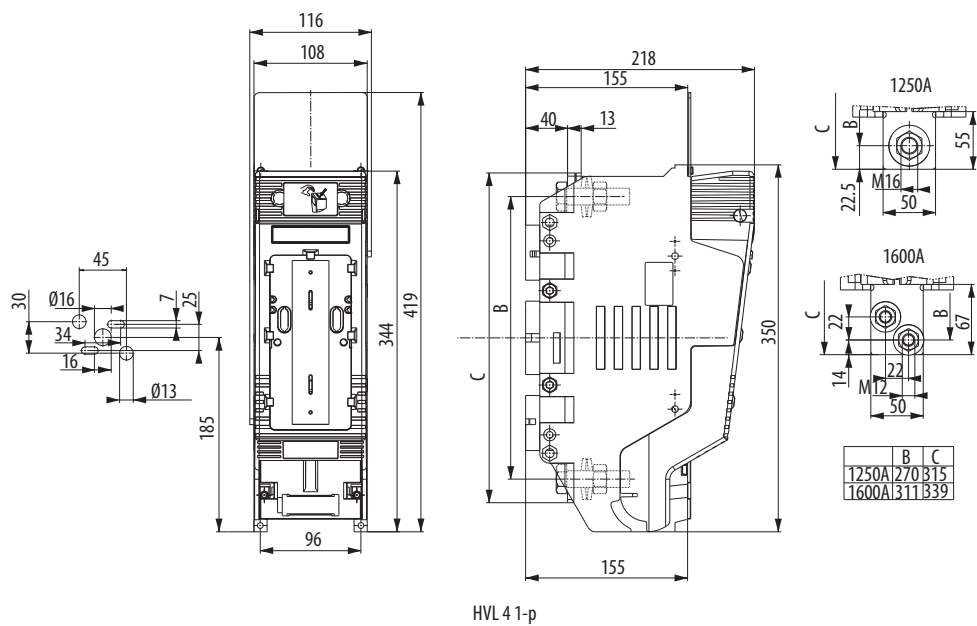
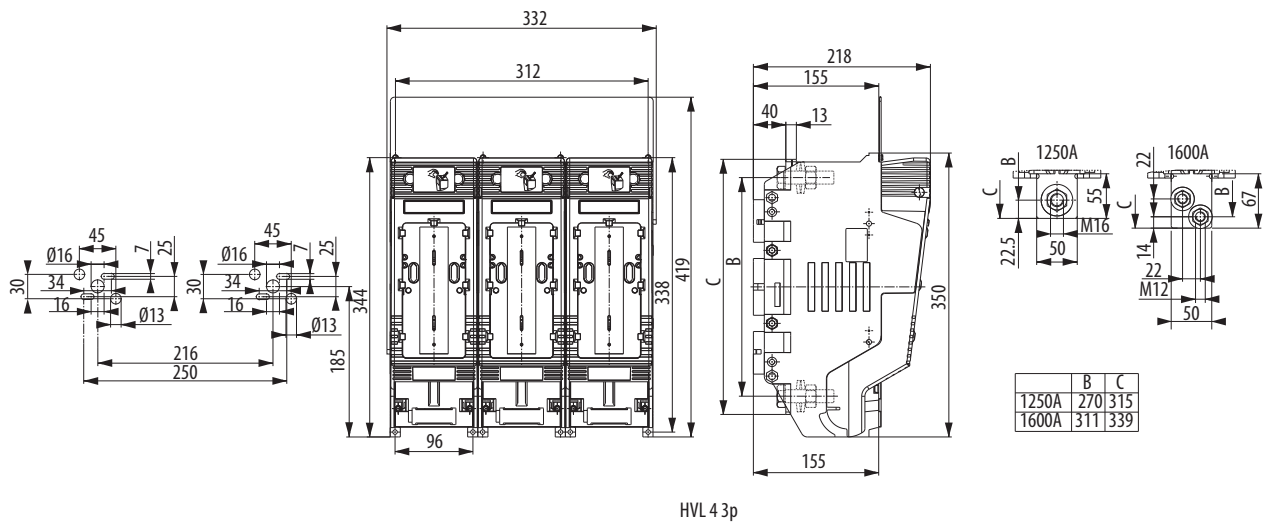
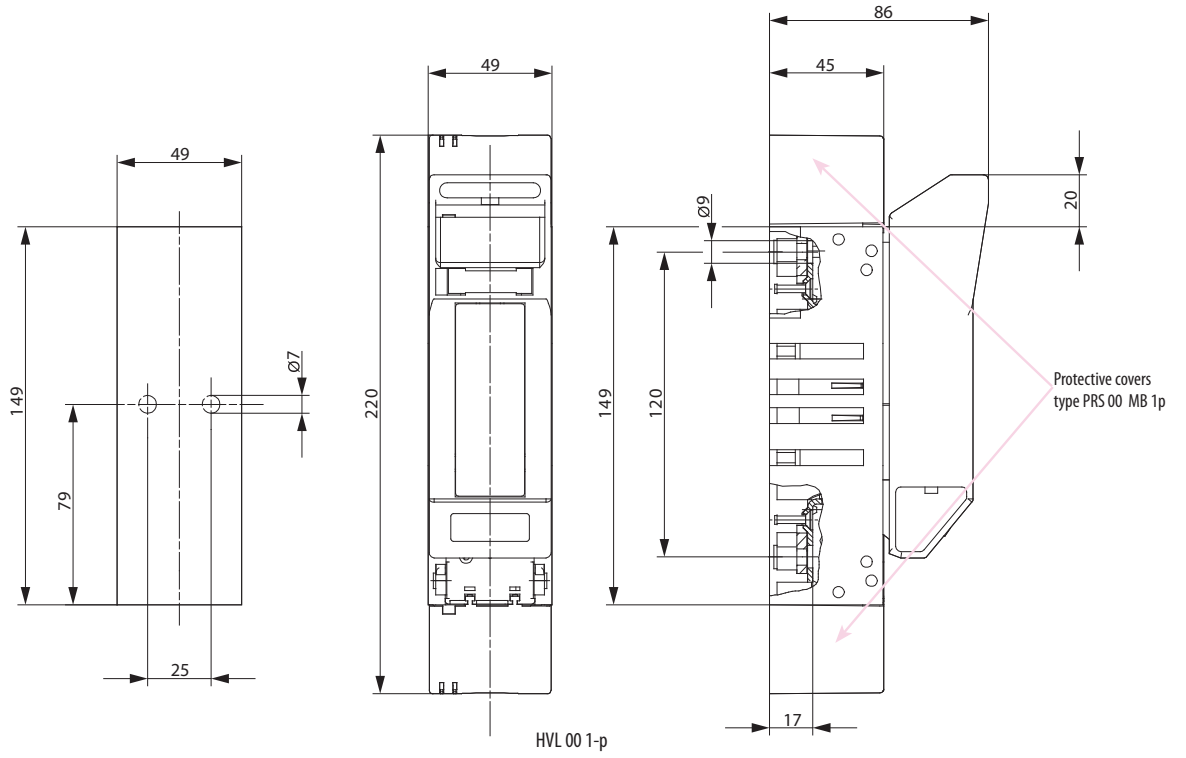

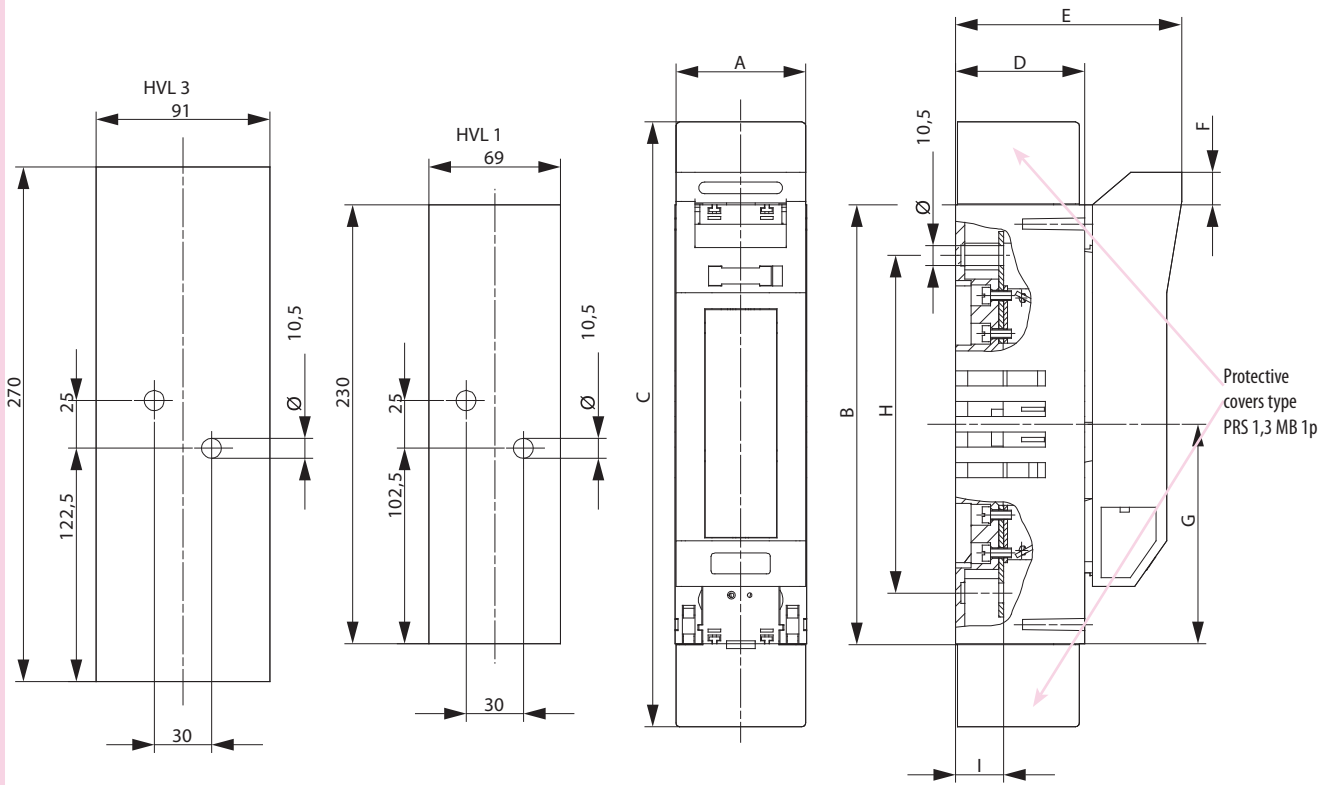

HVL 1 & HVL 3

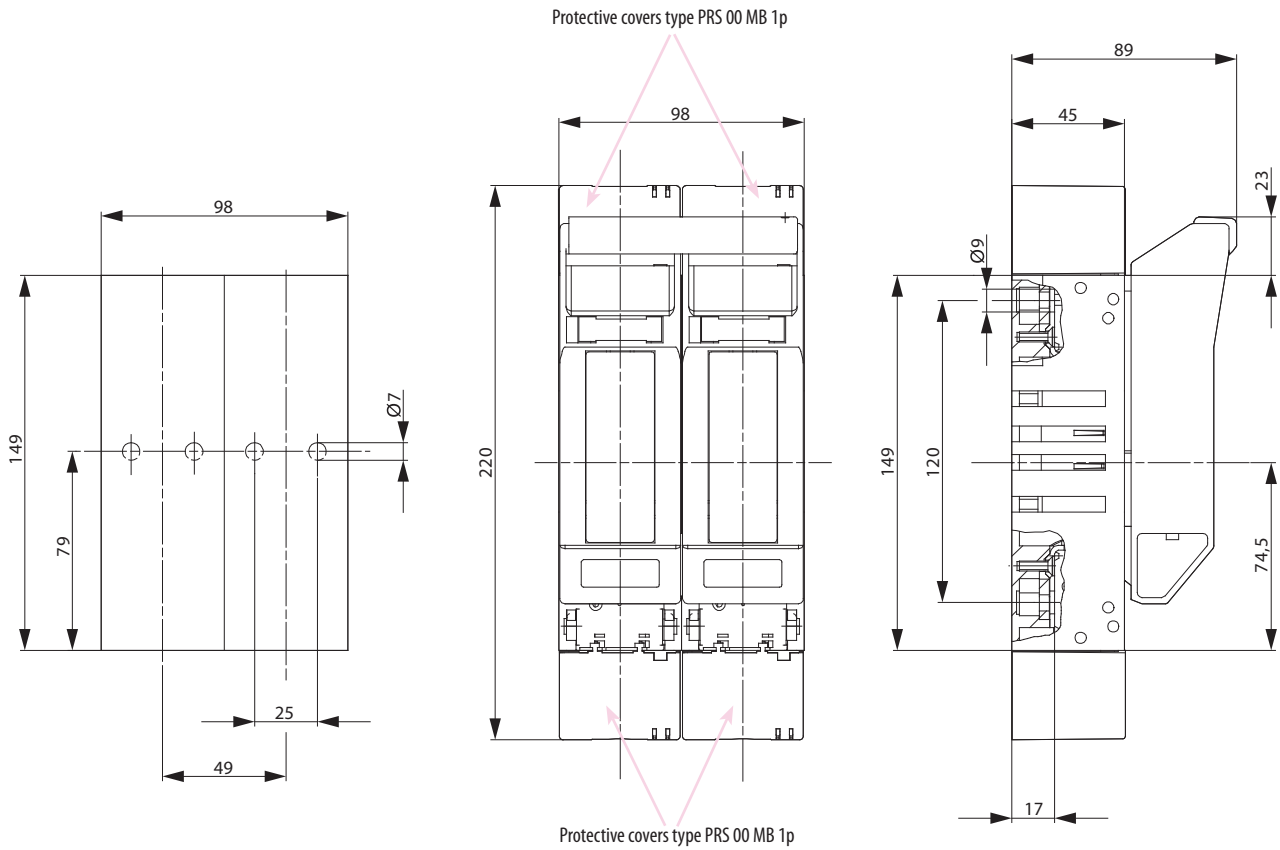

HVL00 2P M8-M8

Technical data

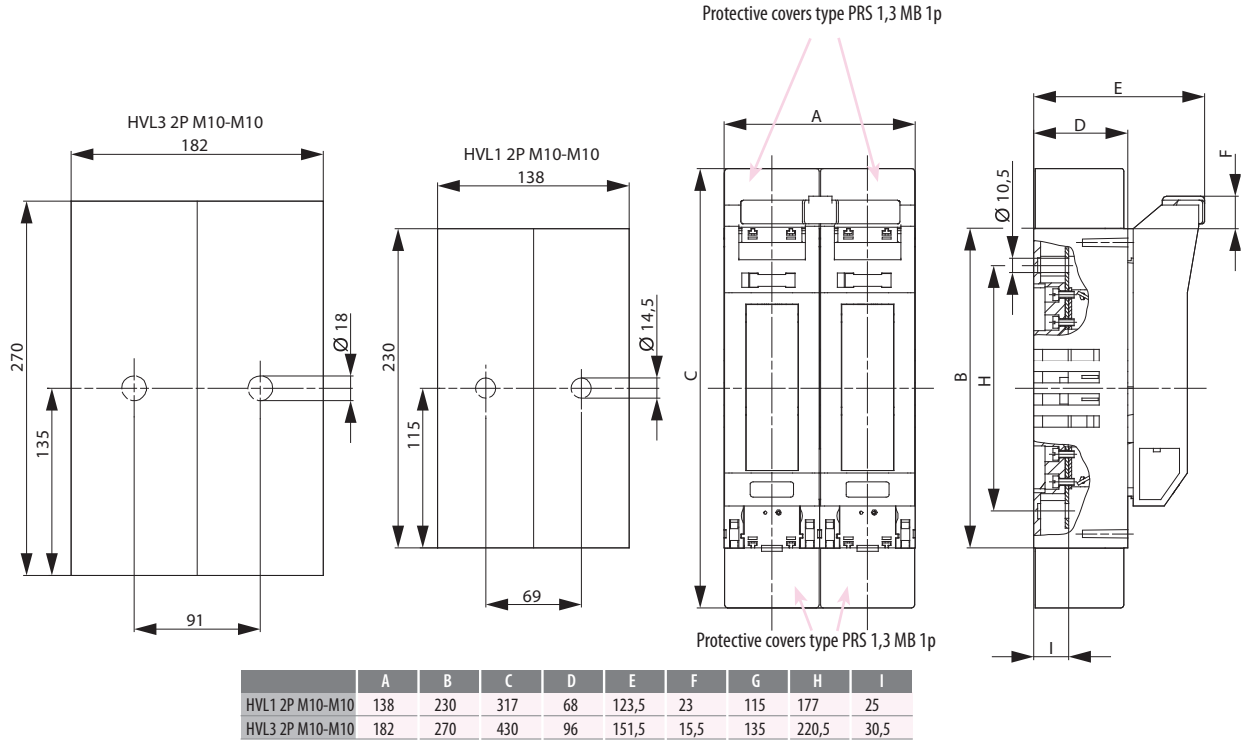

HVL1, 3 2P M10-M10

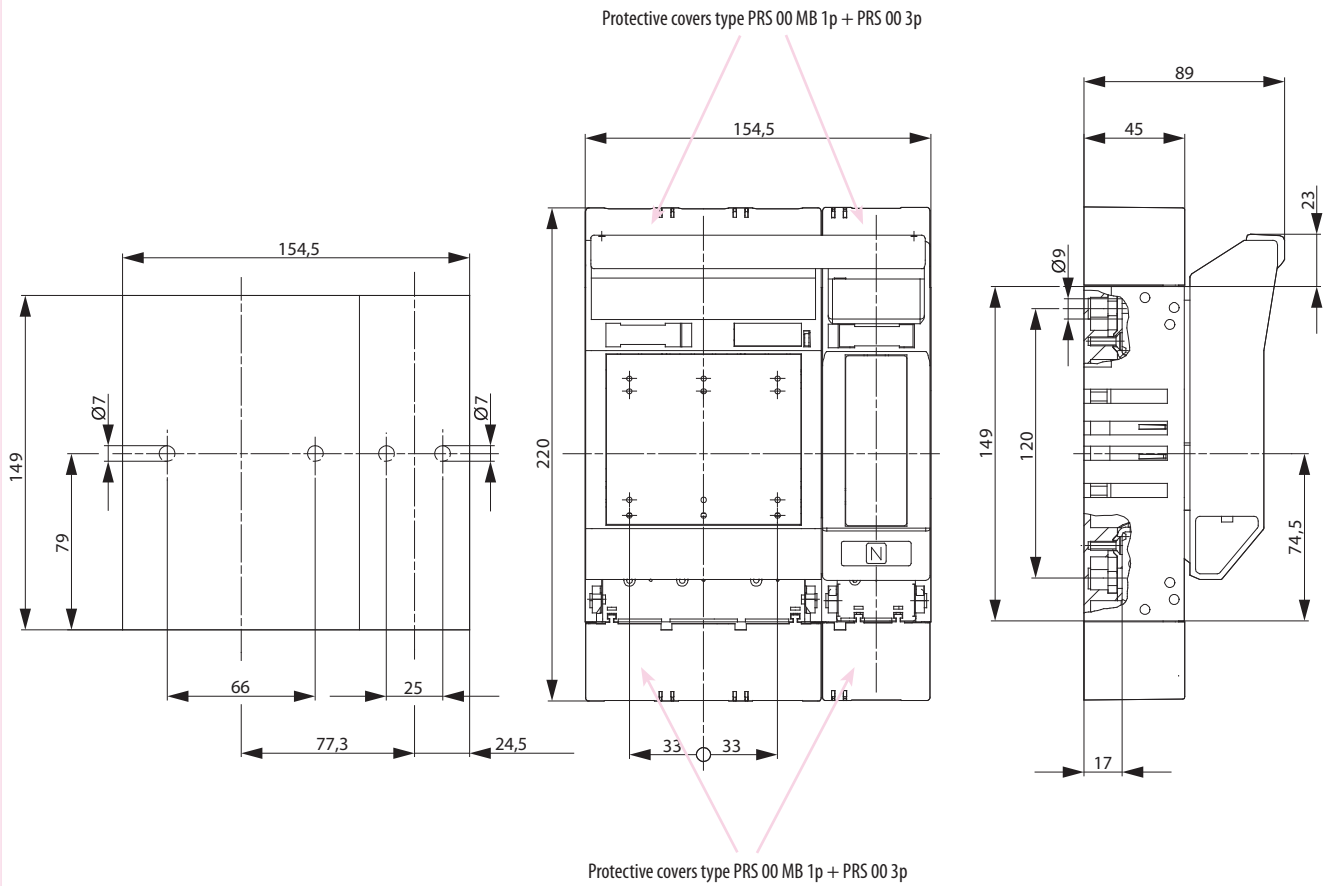

HVL00 4P M8-M8

Protective covers type PRS 1,3 MB 1p + PRS 1,3 3p

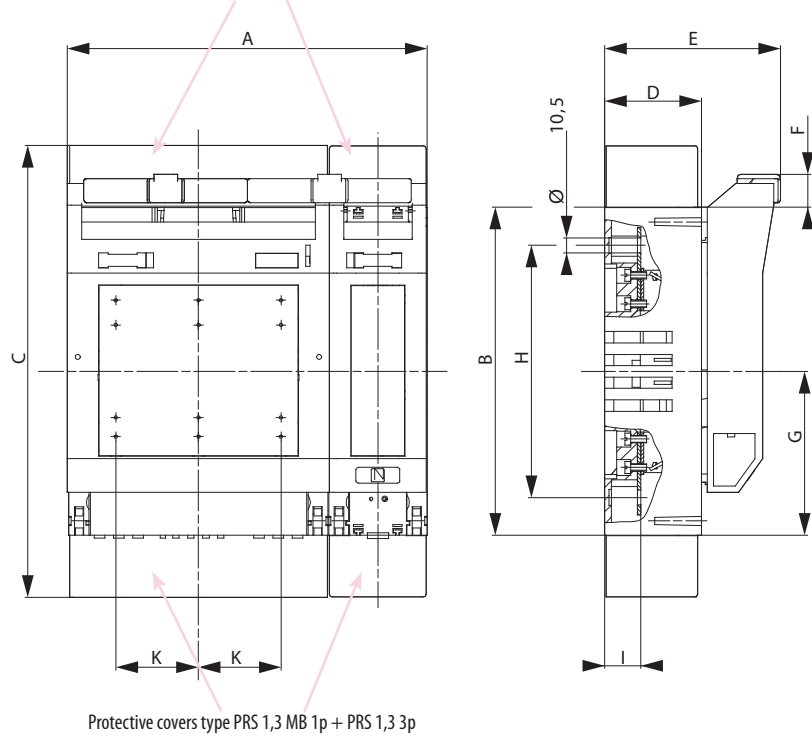
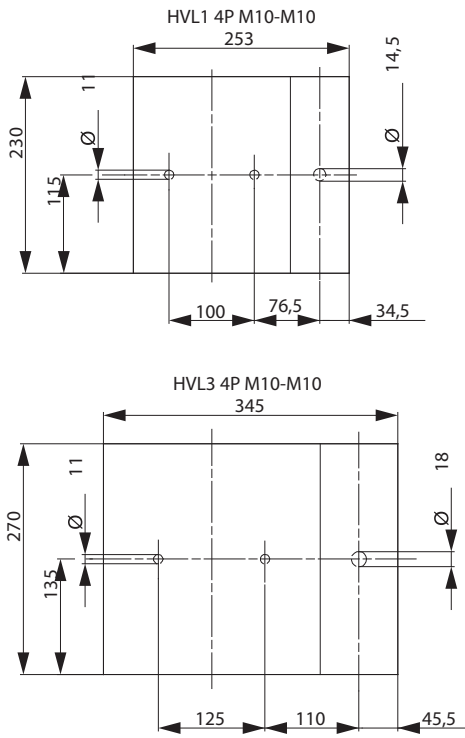

	A	B	C	D	E	F	G	H	I	K
HVL1 4P M10-M10	253	230	317	68	123,5	23	115	177	25	58
HVL3 4P M10-M10	345	270	430	96	151,5	15,5	135	220,5	30,5	82

HVL1, 3 4P M10-M10

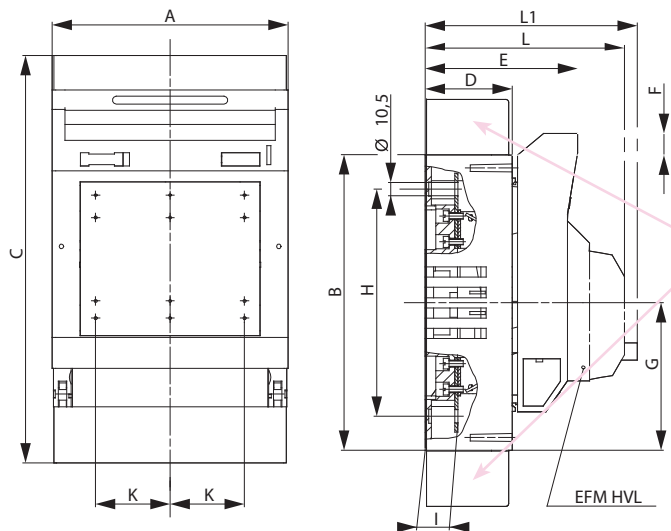
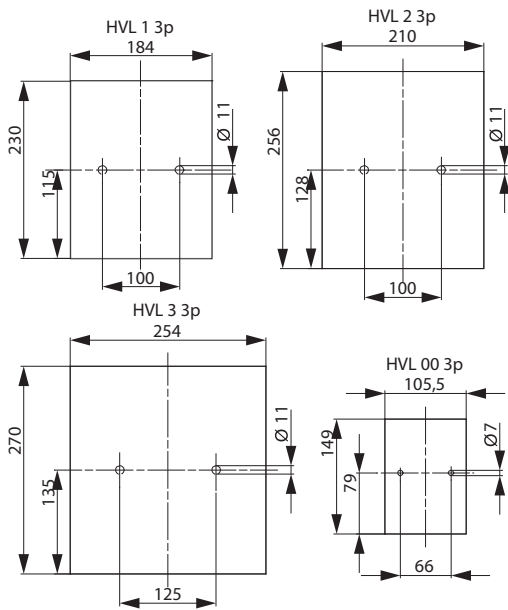

	A	B	C	D	E	F	G	H	I	K	L	L1
HVL00 3p	105,5	149	220	45	86	20,5	74,5	120	17	33	116	126
HVL1 3p	184	230	317	68	119	16,5	115	177	25	58	149	159
HVL2 3p	210	256	397	81	133	16,5	128	205	25	66	163	173
HVL3 3p	254	270	430	96	147	9	135	220,5	30,5	82	177	187

HVL00, 1, 3 - 3p EFM

Protective covers type PRS 00,1,2,3

EFM HVL

Technical data

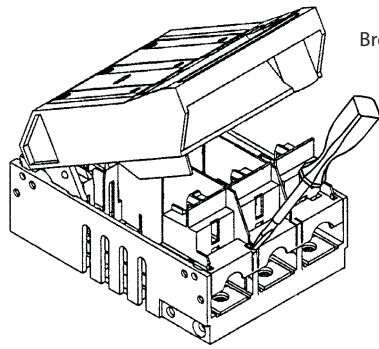

Break off the part on the top protective cover

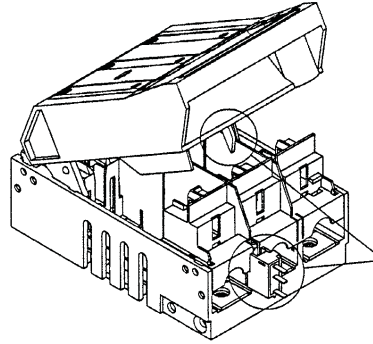

5A / AC 250V
0,35A / DC 110V
0,1A / DC 250V

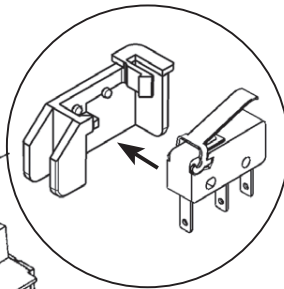
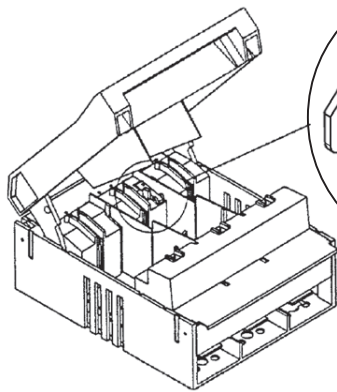
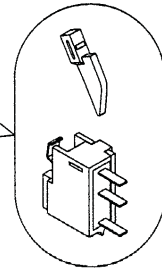
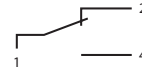

5A / AC 250V
0,35A / DC 110V
0,1A / DC 250V

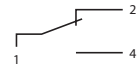

Horizontal fuse-switch disconnecter type HVL EK size 000 and 00

Technical data			HVL EK 000 1p		HVL EK 000 3p		HVL EK 00 1p		HVL EK 00 3p	
Conventional free air thermal current*	I_{th}	A	160							
Rated insulation voltage	U_i	V	AC 690							
Rated withstand voltage	U_{imp}	kV	6							
Rated frequency		Hz	50 (40-60)							
Utilisation category			AC-21B	AC-22B	AC-21B	AC-22B	AC-21B	AC-22B	AC-21B	AC-22B
Rated operational current	I_e	A	160	125	160	100	160	125	160	125
Rated operational voltage	U_e	V	230 AC	690 AC	400 AC	500 AC	230 AC	690 AC	400 AC	500 AC
Rated conditional short-circuit current	kA_{eff}		63							
Mechanical durability (operating cycles)			1600							
Electrical durability (operating cycles)			200							
Power dissipation (without fuse)	W		3,74		10,2		3,74		10,2	
Degree of protection (cover closed)			IP20							
Degree of protection (cover open)			IP10							
Pollution degree			3							
Permissible ambient temperature**		°C	-25 ÷ +55							
Storage temperature		°C	-30 ÷ +70							

* In case of mounting of the fuse-switch disconnecter in cabinet, the thermal current should be corrected (I_{th} x derating factor), depending on the number of built apparatuses (see table 1)

** In case of using the fuse-switch disconnecter at temperatures +45°C to +55°C, the thermal current I_{th} should be reduced for 5%-10%

Table 1

Number of built apparatuses	2 - 3	4 - 5	6 - 9	>9
Derating factor	0,9	0,8	0,7	0,6

HVL EK 000 1p

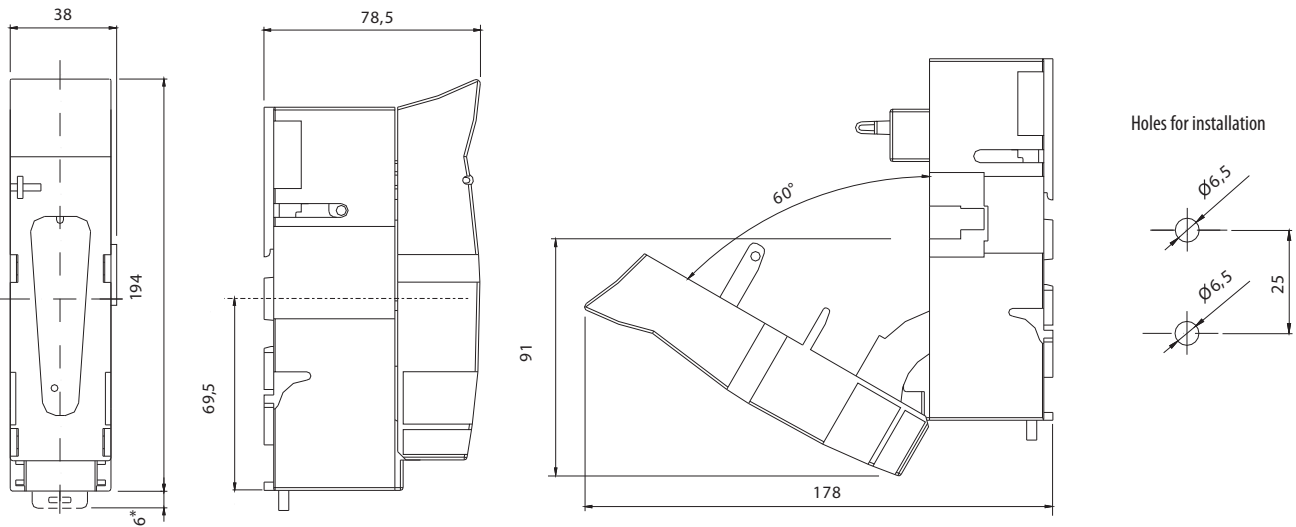

NV/NH

Technical data

HVL EK 000 3p

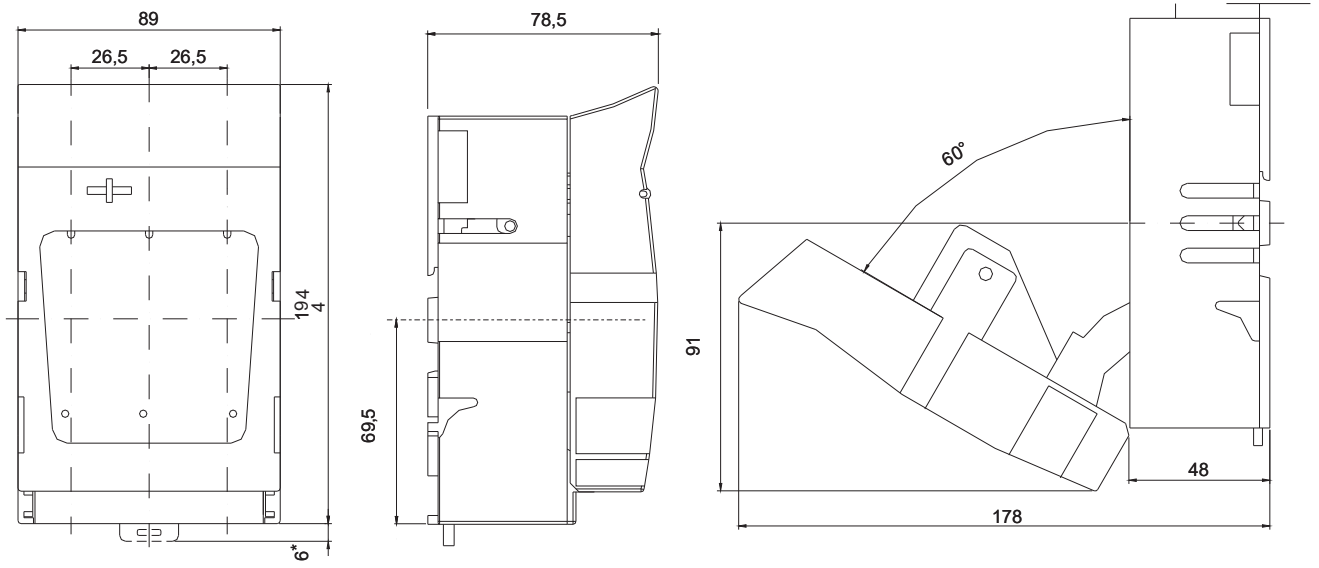

Holes for installation

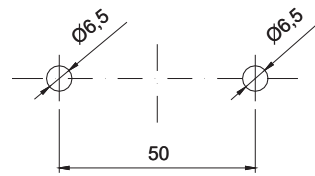

HVL EK 000 4p

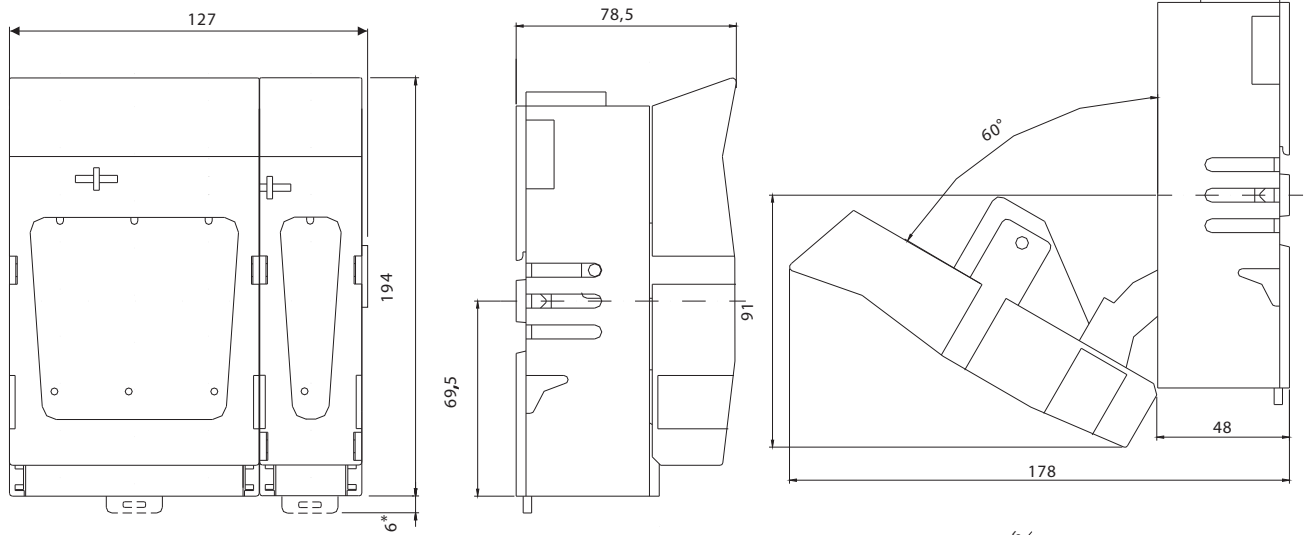

Holes for installation

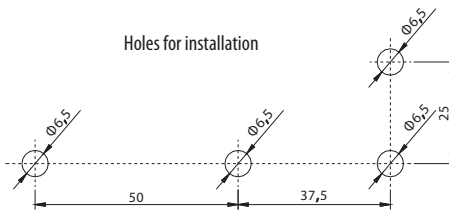

HVL EK 000 – options and Installation guide

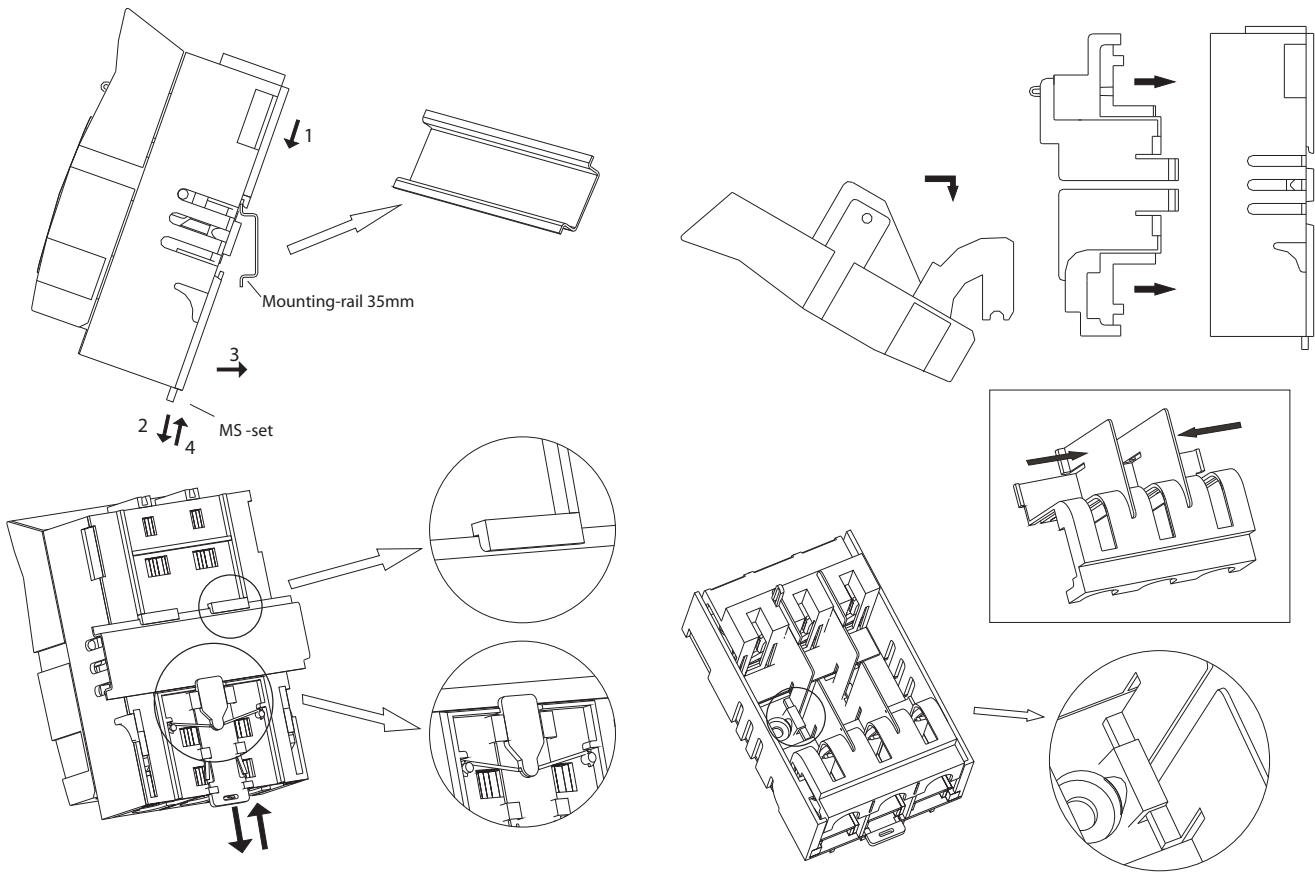

HVL-B EK 000 3p

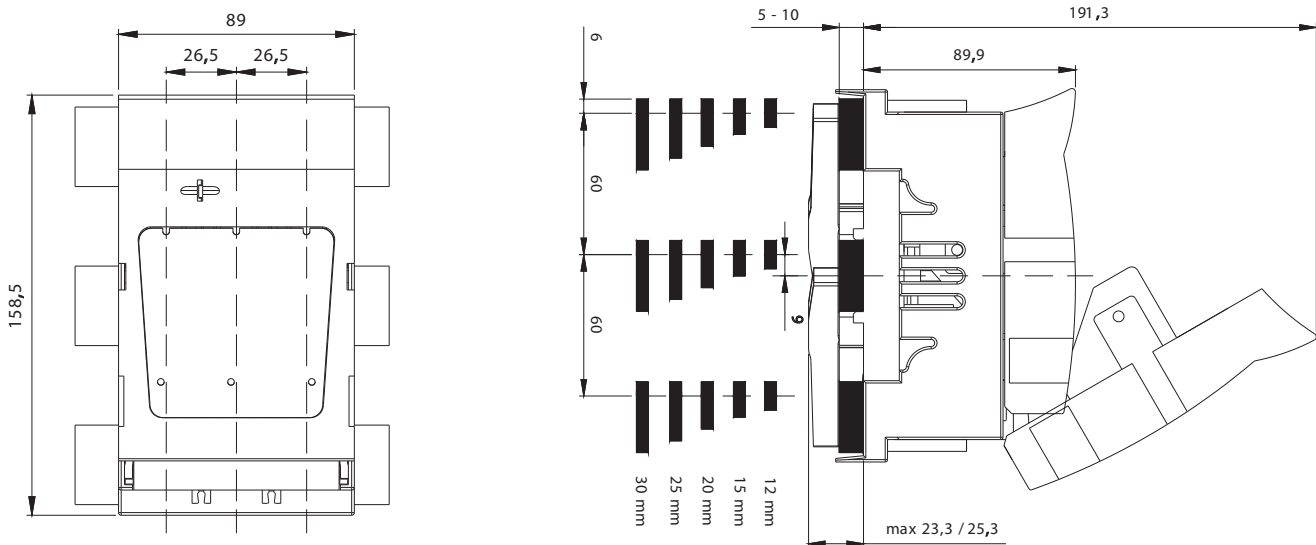

NV/NH

Technical data

HVL-P EK 000 3P

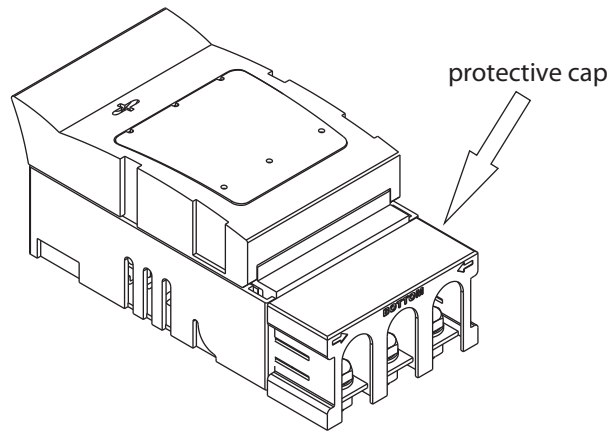
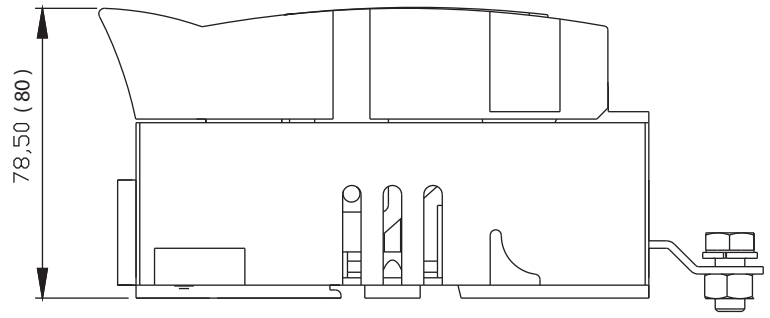
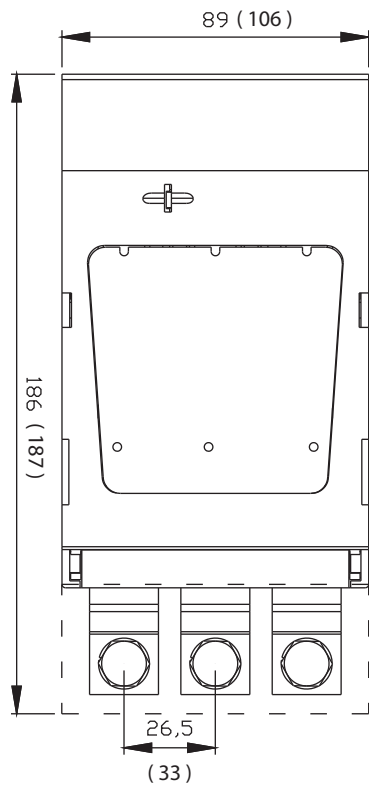

Holes for installation

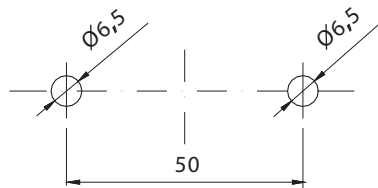

HVL-P EK 000 3p is supplied complete with a bottom covering protection. HVL-P EK 00 3p is supplied without protective coatings.

HVL EK 00 1p

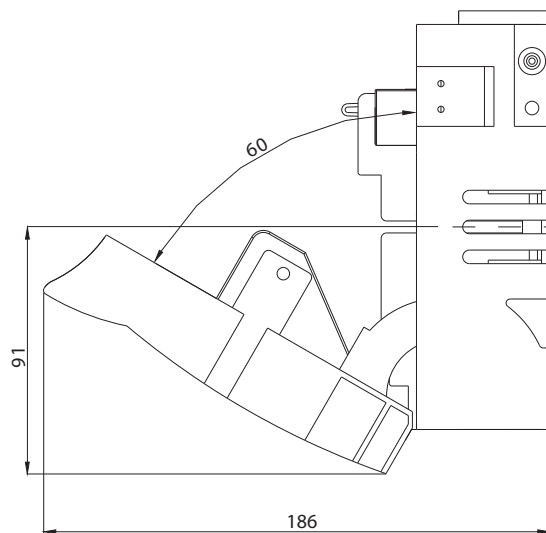
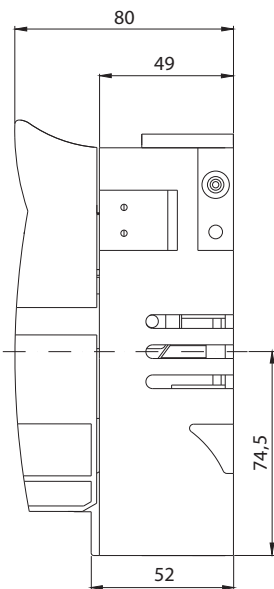
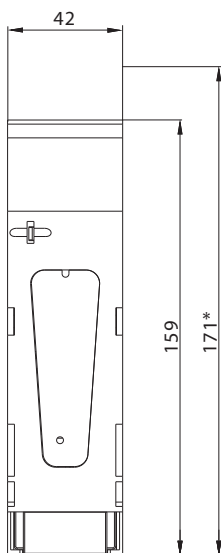

Holes for installation

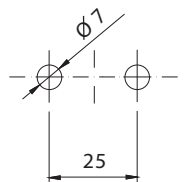

HVL EK 00 3p

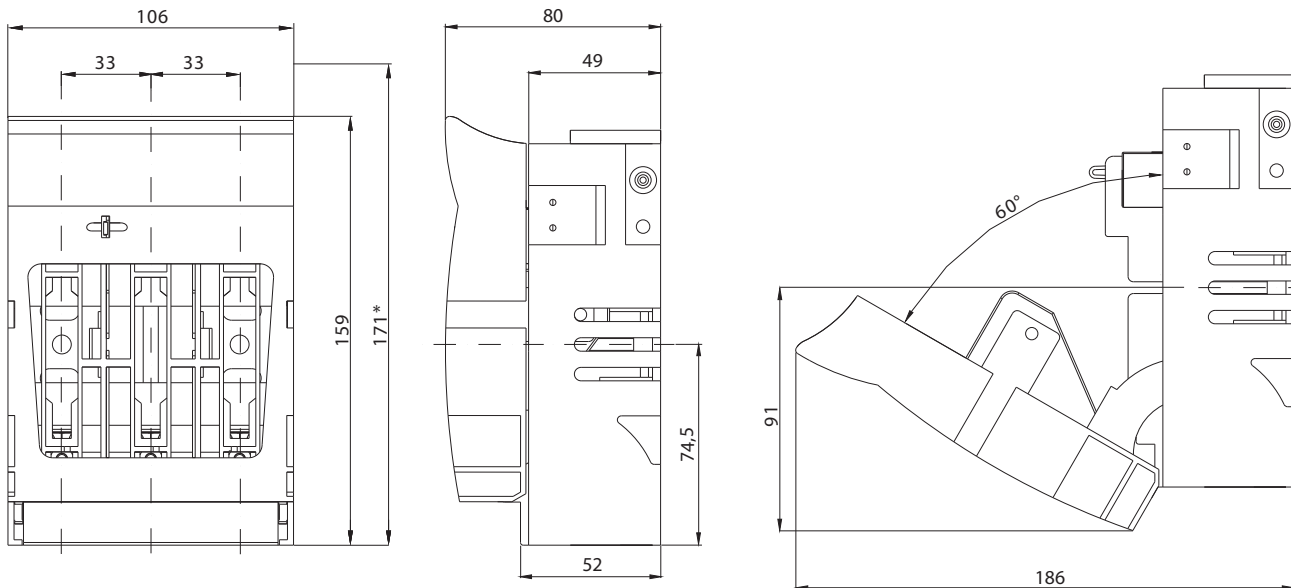

Holes for installation

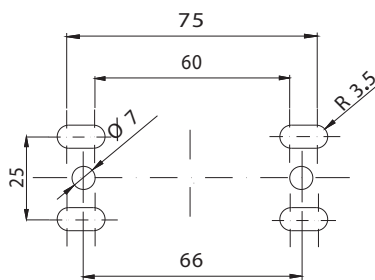

HVL EK 00 4p

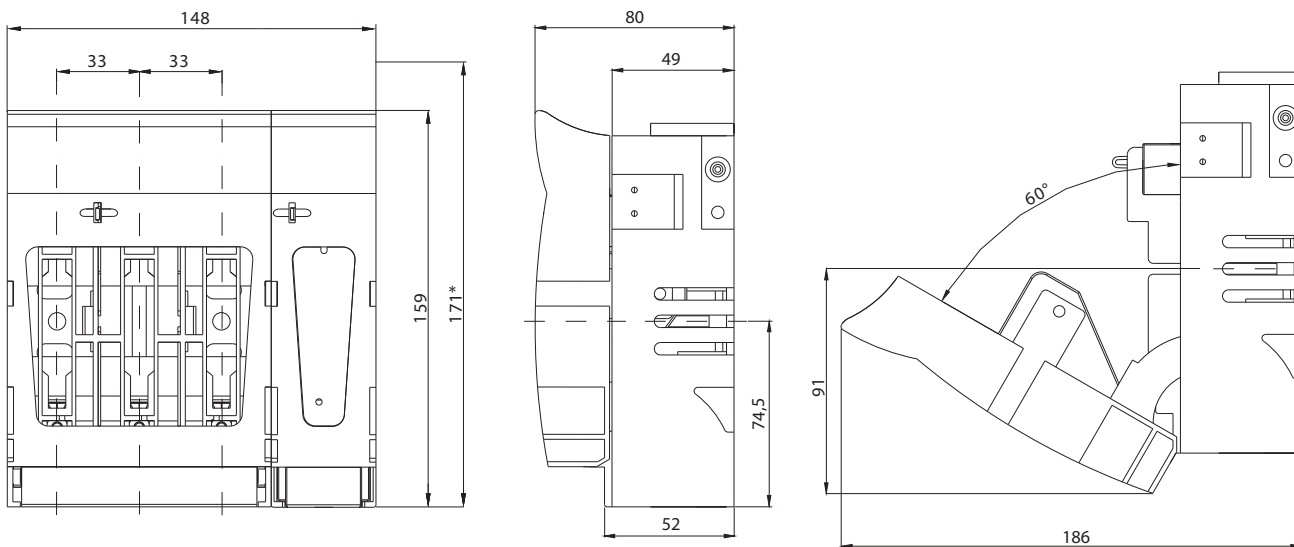

Holes for installation

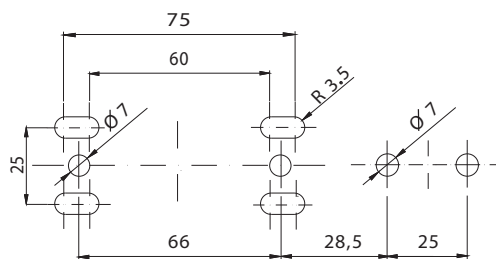

* with set for mounting on two mounting rails in distance (125mm, 150mm)